

PORTABLE IMAGE

WHEEL ALIGNER



Parts Manual

All information contained or disclosed in this document is considered confidential and proprietary by Snap-on Equipment. All manufacturing, use, reproduction, and sales rights are reserved by Snap-on Equipment and the information contained herein shall not be used in whole or in part without the express written consent of Snap-on Equipment.

Table of Contents

ALIGNER ASSEMBLY.....	2
CABINET ASSEMBLY	3
CABINET ASSEMBLY	4
ELECTRICAL SHELF ASSEMBLY	6
POD ASSEMBLY	8
TARGET ASSEMBLY SERVICE.....	9
WHEEL CLAMP ASSEMBY	10
WAP.....	12

ALIGNER ASSEMBLY

EEWA557A - JBC / EEWA717A - Hofmann (North America)

EEWA555A - JBC / EEWA719A - Hofmann (Europe)

QTY	PARTNUMBER	DESCRIPTION
1	EAL0392J66A	DECAL-JBC 9 IN
1	EAL0392J72A	DECAL-HOFMANN
1	EAL0392J76A	DECAL-PRISM CONSOLE EL
1	EAK0268J05A	PRINTER KIT-USB
1	3-03506A	PRINTER-COLOR INKJET
1	00088910000	PRINTER-PAPER 1146030
1	6-02422B6	CABLE-USB 6' A MALE TO B MALE
1	5-10426A1	TAPE-HOOK VELCRO #88
1	5-10426A2	TAPE-LOOP VELCRO #1000
1	00089209000	CORD-POWER ADAPTER 12
1	88931000	POWER CORD/LABEL ASS'Y 115V
1	EAL0392J61A	PAD-MOUSE
1	EAK0277J82A	LIT PACK-GENERIC
1	96000	DEPRESSOR ASS'Y-PEDAL
1	55502000	CLAMP ASS'Y-WHEEL STEERING
1	EAA0337J81C	CABINET-EL BASIC JBC
1	EAA0353J09B	CABINET-EL BASIC HOFMANN
1	3-02408A	MONITOR-15 CRT
1	EAA0353J05A	PC ASSY-GENERIC III
1	3-40026C	SFTWR-KEY DISK,JBC
1	3-40126C	SFTWR-KEY DISK, HOF
1	EAK0289J22A	KIT-CLAMP BRACKET (4)
2	EAC0079J62A	CHOCK-WHEEL
2	88635000	POWER CORD-3 COND IEC-301

CABINET ASSEMBLY

EAA0337J81C

EAA0353J09B

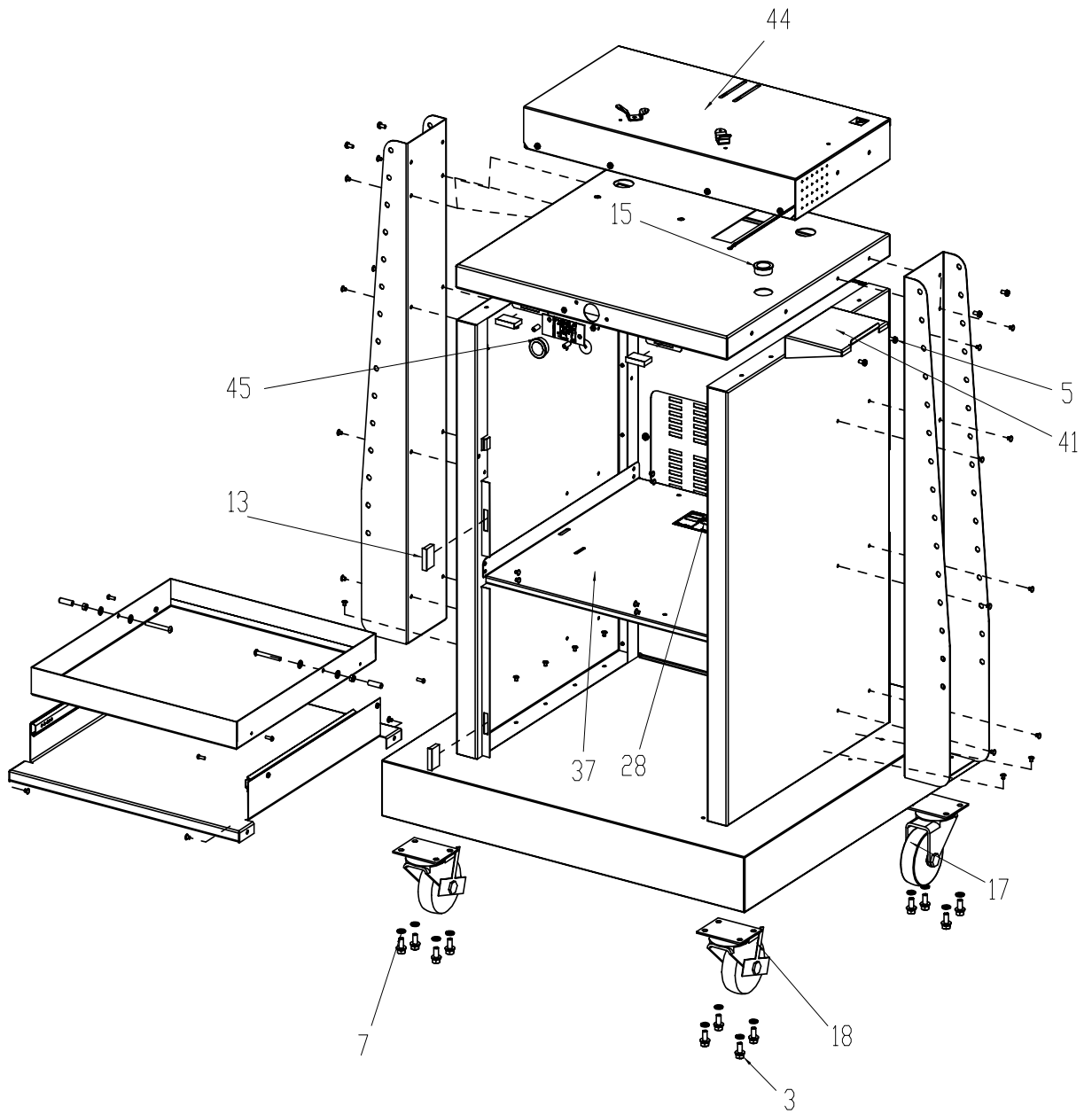

CABINET ASSEMBLY

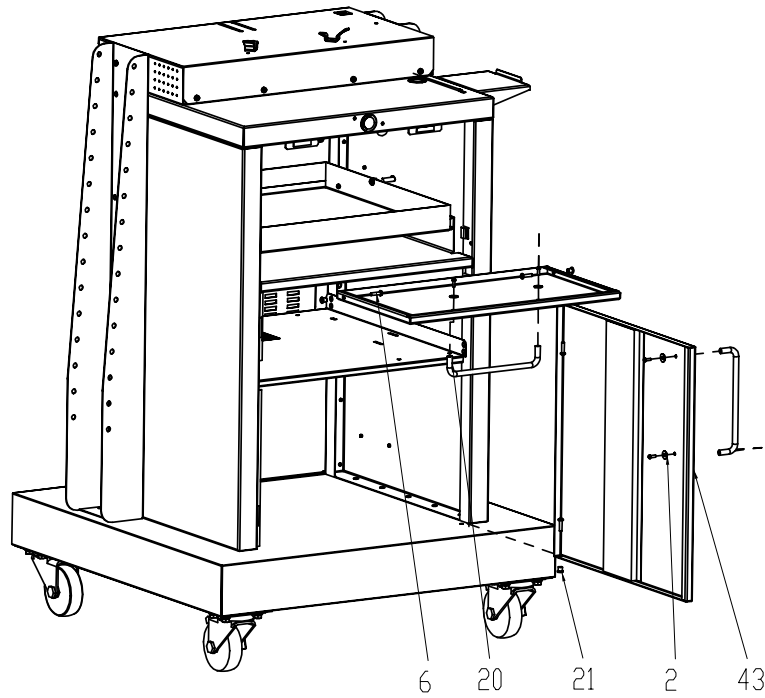
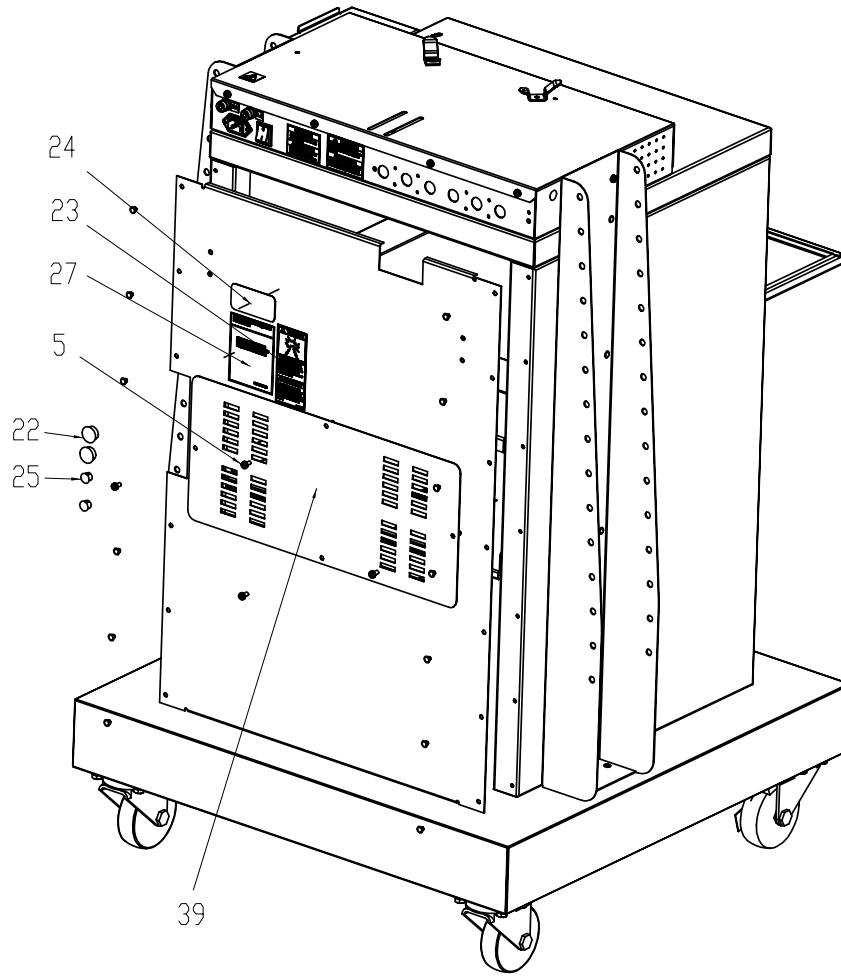

CABINET DESCRIPTION

SYM	REQD	PART NO	DESCRIPTION
2	2	1-18941A	WASHER-FLAT, .195 X .619 X .06 THICK
3	16	1-13501A	SCREW, HEX M8X20ST/FT
5	10	1-16006A	SCREW-M5X12MM PAN HD, BLK
6	2	1-25306A	PHMS, M5 X 20MM
7	16	1-446	LOCKWASHER
8	2	1-38909A	BHCS, M4 X 12MM
13	2	8-03642A	MAGNETIC CATCH
15	2	8-08116A	BUSHING-SNAP 16/16ID,29/64LG
17	2	8-28839A	CASTOR-SWIVEL 4"
18	2	8-28939A	CASTOR-SWIVEL 4" WITH BRAKE
20	1	8-11133A	HANDLE- PC/PRINTER SHELF DOORS
21	2	1-5665	BUSHING - SHOULDER, NYLON
22	2	1-1376	PLUG, .75 DIA.
23	1	111243	LABEL-WARNING EXPLOSION
24	1	EAL0343J76A	ELECT/SERIAL LABEL
25	2	1-2376	HOLE PLUG
27	1	EAL0392J18A	LABEL-PATENT ALIGNMENT
28	1	EAL0392J58A	LABEL-USB LOCATION
37	1	EAS2091J74A	TRAY - PC SHELF UNIVERSAL CONSOLE
39	1	EAS2091J82A	ACCESS PANEL - PC SHELF UNIV. CONSOLE
41	1	EAS2091J85A	MOUSE - TRAY UNIVERSAL CONSOLE
43	1	EAS2091J94A	DOOR ASSY - PC SHELF
44	1	EAA0337J92A	ELECTRICAL SHELF ASSY - BASIC
45	1	1-06976A	HOLE PLUG
50	2	88635	POWER CORD - 3 COND IEC

ELECTRICAL SHELF ASSEMBLY

EAA0337J92A

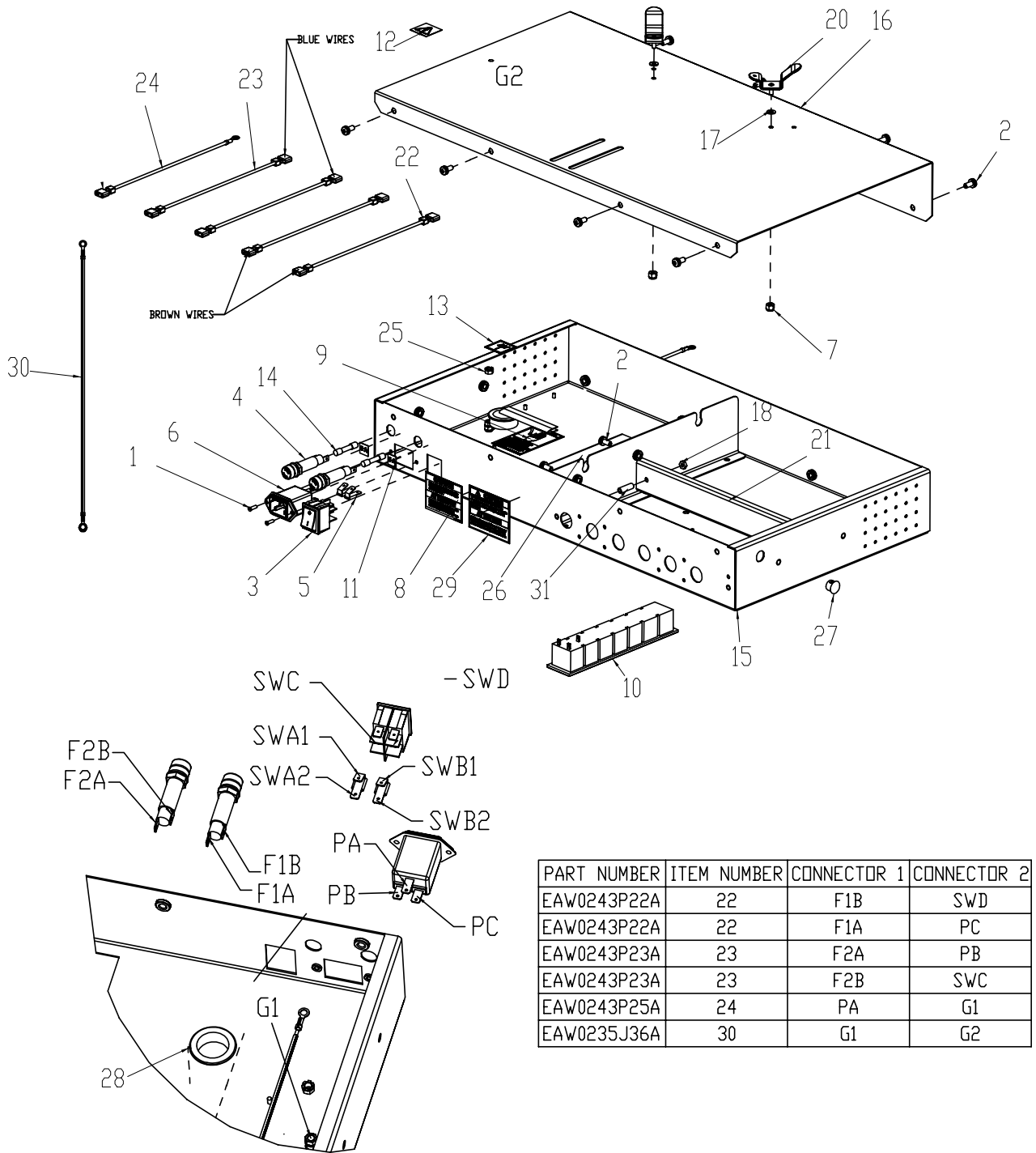

SYM	REQD	PART NO	DESCRIPTION
1	2	1-11103	M3 X 10MM FLAT HEAD SCREW
2	10	1-16006A	SCREW-M5X12MM PAN HD, BLK
3	1	2-12258A	SWITCH, ROCKER
4	2	2-15651A	FUSE HOLDER
5	2	2-31001A	TERMINAL - QUICK CONNECT
6	1	2-37348A	AC RECEPTACLE & LINE FILTER (IEC)
7	2	1-01737A	NUT-ESNA,M4
8	1	86164	LABEL-WARNING, FUSE RATING
9	1	86465	LABEL-WARNING, SHOCK HAZARD
10	1	EAA0261P60A	IEC POWER BLOCK ASSY
11	2	EAL0345P51A	LABEL FUSE 5 A
12	1	EAL0345P54A	ELECTRICAL WARNING LABEL
13	1	EAL0392J19A	LABEL-GROUND
14	2	2-18451A	FUSE - 5A SLOW BLOW
15	1	EAS2091J95A	ELECTRICAL BOX ASSY UNIVERSAL CONSOLE
16	1	EAS2091J96A	PANEL ASSY - CRT ELECTRICAL BOX
17	2	1-4044	WASHER - FLAT, NYLON .031 THK
18	2	1-9733	NUT-M4 ZINC
19	1	1-03083A3	TRIM - FLEXIBLE
20	2	EAS2048J41A	BRACKET-MONITOR, FRONT ASM.
21	1	EAS2091J99A	PLATE - COVER ELECT BOX ASSY
22	2	EAW0243P22A	LINK WIRE, BROWN
23	2	EAW0243P23A	LINK WIRE, BLUE
24	1	EAW0243P25A	LINK WIRE, GRN/YEL
25	3	1-13633A	BARB NUT M5
26	1	EAS2091J29A	BRACKET
27	1	1-2376	HOLE PLUG
28	1	8-08116A	BUSHING-SNAP 16/16ID,29/64LG
29	1	111245	LABEL-CAUTION, ELECTRICAL
30	1	EAW0235J36A	CABLE ASSY- GROUND, 12"
31	2	1-5962	NYLON ROUND STANDOFF 3/4"
*	1	2-50166A	POWER SUPPLY - 9V
*	1	EAW0235J68A	POWER CORD (POWER SUPPLY)
*	2	2-31001A	QUICK CONNECT TERMINALS
*	1	6-06822A	ETHERNET CABLE

* PARTS NOT SHOWN IN ILLUSTRATION AND ARE ORDERED SEPARATELY FROM THE EAA-0337J92A ELECTRICAL SHELF ASSEMBLY.

POD ASSEMBLY

FIELD SERVICE KITS

EAK0289J43A - SENSOR POD KIT, JBC

EAK0289J44A - SENSOR POD KIT, HOFMANN

EAK0289J34A Sensor Pod Kit, (No brand)



ITEM	REQD	PART NO	DESCRIPTION
1	1	EAC0090J40A	BUMPER - COVER. CAMERA
2	1	EAC0090J41A	BUMPER - CROSS TOE
3	1	EAC0090J44A	PIVOT BUMPER
4	2	EAM0054J55A	CW - OUTSIDE,
5	1	EAC0090J81A	BUMPER LOWER BATTERY
NS	1	EAA0337J64A	BATTERY PACK

NOTE: NO FIELD SERVICE PARTS INSIDE OF POD

TARGET ASSEMBLY SERVICE
EAK0289J13A - KIT - TARGET ASSY. SVO LEFT

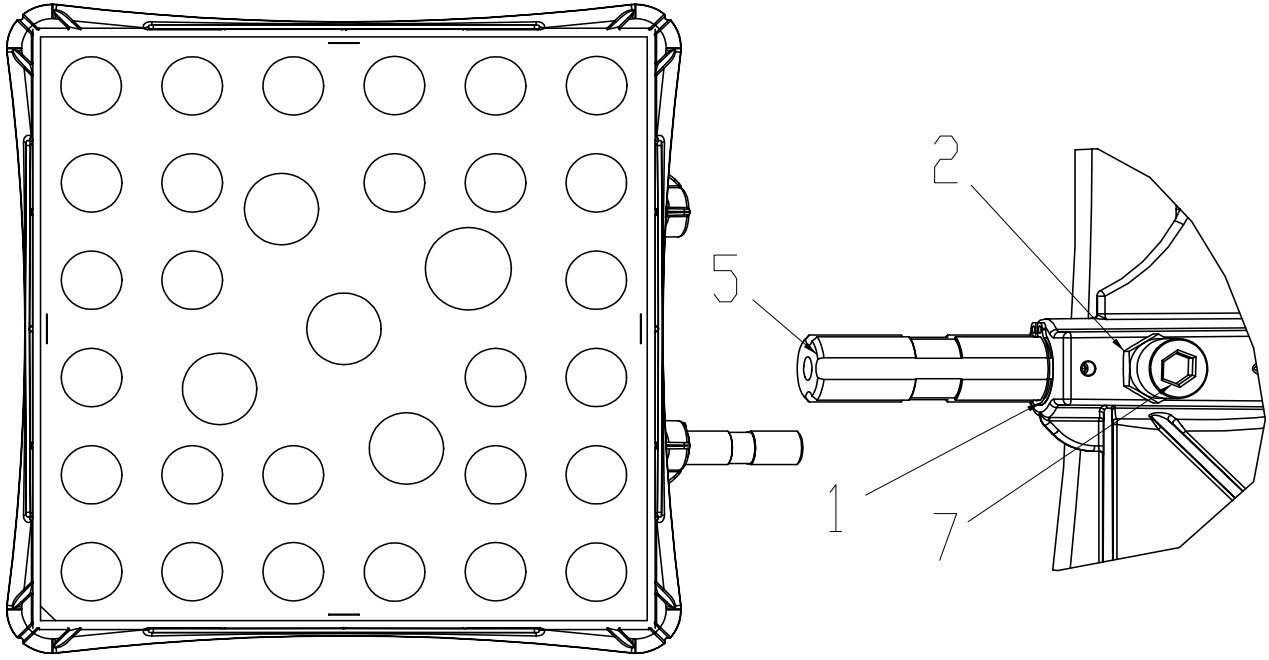

SYM	REQD	PART NO	DESCRIPTION
1	1	1-13677A	RING-RETAINING
2	1	1-20733A	NUT - JAM, M8
5	1	EAM0047J79A	SHAFT - TARGET, 10"
7	1	EAM0054J48A	SCREW - SHAFT TARGET

NOTE: THE SHAFT CAN BE MOVED IN THE HOUSING TO CONVERT THE LEFT TARGET TO A RIGHT TARGET.

WHEEL CLAMP ASSEMBLY
EAK0289J15A - EUROPE (EUR)
EAK0289J11A - NORTH AMERICA (NA)

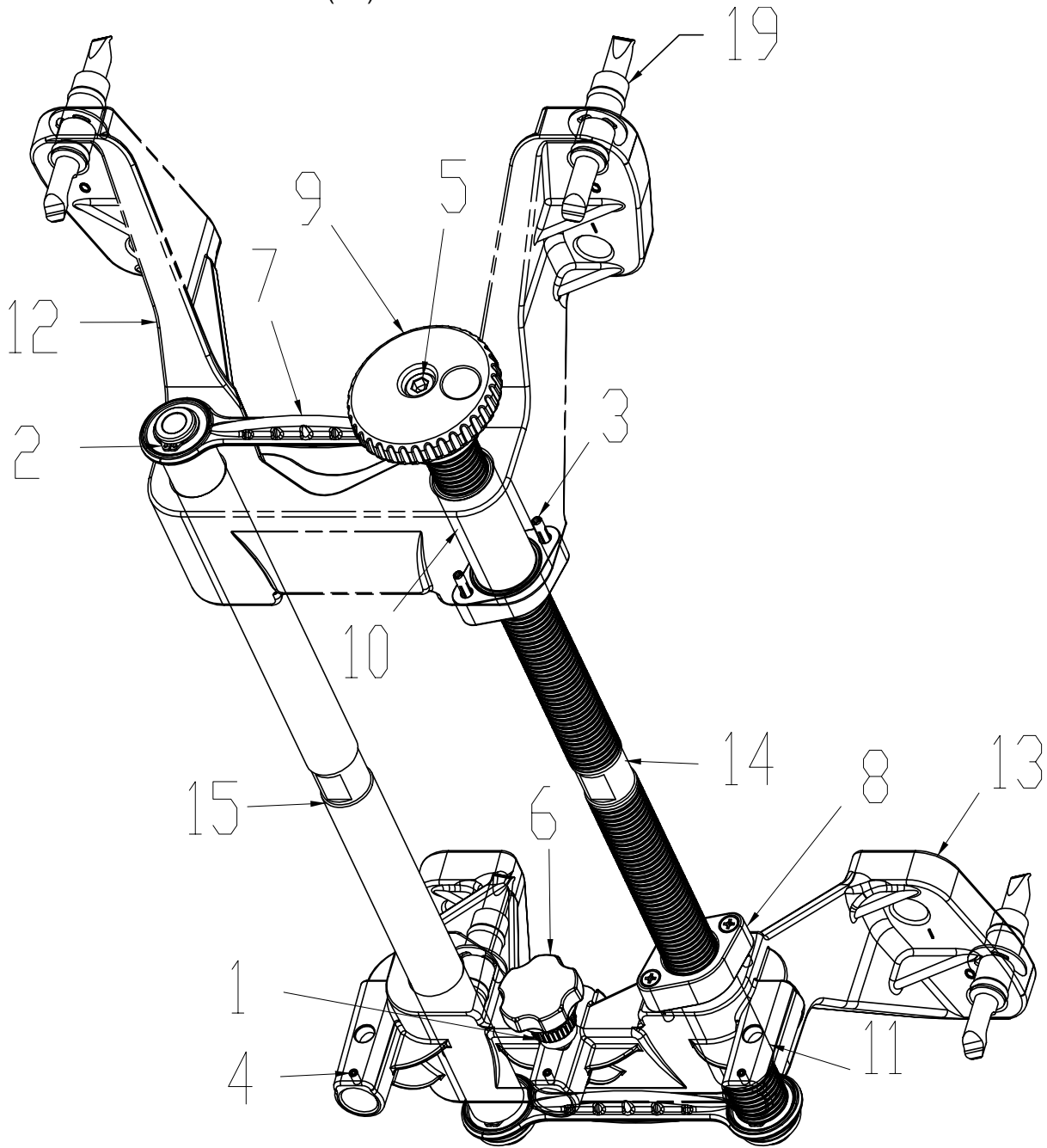

NOTE: KIT CONTAINS WHEEL CLAMP,
4 GRABBERS & BUNGEE CORDS

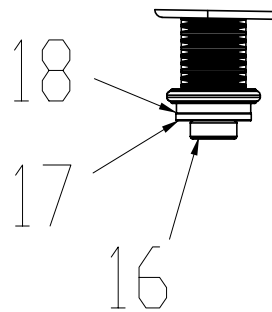

SYM	REQD	PART NO	DESCRIPTION
1	1	1-02612A	M8 THUMB SCREW
2	6	1-20077A	RETAIN - RING, WC
3	4	1-34806A	SCREW - FLAT PHM, M4 X 25MM
4	3	1-53110A	SCREW-SET M3 X .5 X 6MM, CUP PT.
5	1	1-55909A	SCREW - SHC, M8 X 35MM
6	1	EAC0055J46A	KNOB-SHAFT CLAMP
7	2	EAC0090J50A	BRACKET - GUIDE ROD
8	2	EAC0090J52A	COVER - HOLDER, BUSHING
9	1	EAC0090J56A	KNOB - CAST, WC
10	1	EAM0054J26A	BUSHING - WC, RIGHT
11	1	EAM0054J27A	BUSHING - WC, LEFT
12	1	EAM0054J39A	BRACKET - UPPER, LONG
13	1	EAM0054J41A	BRACKET - LONG. LOWER, WC
14	1	EAM0054J58A	ROD - LEAD SCREW MACH. - EUR
	1	EAM0054J49A	ROD - LEAD SCREW MACH. - NA
15	1	EAM0054J59A	ROD - GUIDE, MACH., EUR
	1	EAC0090J58A	ROD - GUIDE, MACH., NA
16	2	1-47709A	SHCS - M10 X 20MM
17	2	1-5741	WASHER, PLAIN 3/8
18	2	EAS2105J11A	WASHER - SPACER, WC
*	1	EAK0289J40A	STABILIZER KIT
*	1	EAK0268J41A	WHEEL GRABBER KIT (4 GRABBERS) NOT PART OF WHEEL CLAMP ASSEMBLY
	1	1-08584A	BUNGEE CORD (NOT PART OF WHEEL CLAMP ASSEMBLY)



EAA0337J80A - WAP ASSEMBLY
EAW0235J70A CHARGING CABLE ASSEMBLY

NOTE: NO FIELD SERVICE PARTS INSIDE WIRELESS ACCESS ASSEMBLY

CALIBRATION HARDWARE

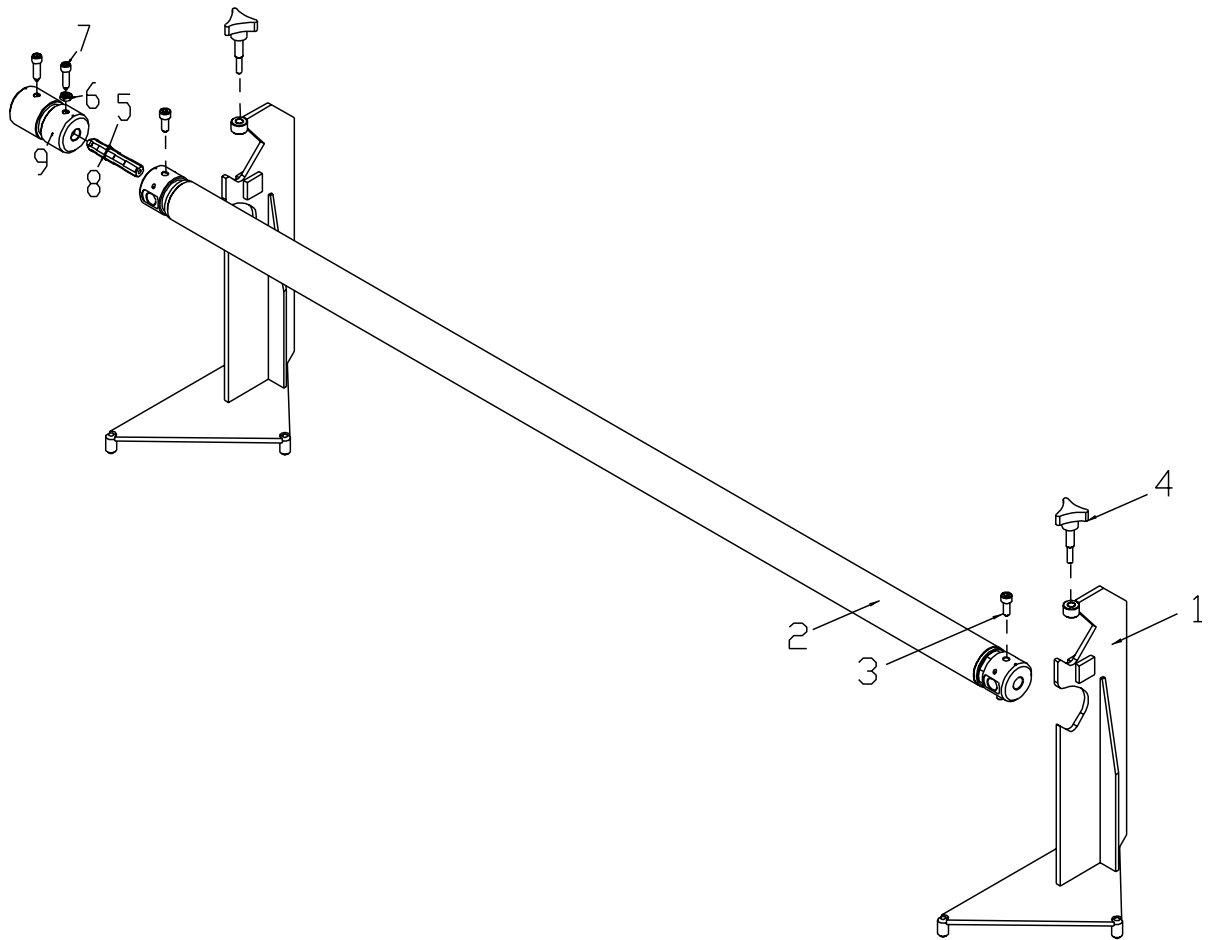

REF	QTY	PART NUMBER	DESCRIPTION
1	2	EAA0256J17A	CALIBRATION STAND
2	1	EAC0055J11A	BAR ASS'Y - CALIBRATION
3	2	EAM0007J19A	SCREW - SHAFT CLAMP
4	2	EAM0007J34A	KNOB, CLAMP - CALIBRATION BAR
5	1	1-13677A	RING-RETAINING
6	1	1-20733A	NUT - JAM, M8
7	2	EAM0007J19A	SCREW - SHAFT CLAMP
8	1	EAM0047J79A	SHAFT - TARGET, 10"
9	1	EAM0054J73A	ADAPTER - CAL. BAR, PRISM

Notice: The information contained in this document is subject to change without notice. Snacon Equipment makes no warranty with regard to this material. Snacon Equipment shall not be liable for errors contained herein or for incidental consequential damages in connection with furnishings, performance, or use of this material.

This document contains proprietary information which is protected by copyright and patents. All rights are reserved. No part of this document may be photocopied, reproduced, or translated without prior written consent