



Models:

- | | |
|---------|---------|
| AR55-51 | AR55-45 |
| SM40-43 | AR40-43 |
| SM55-51 | SM55-45 |
| SM55W51 | AR55W51 |

IMPORTANT: When ordering parts or requesting service always give exact model and power unit serial number. Model number is shown on nameplate attached to air lock release valve. Power unit serial number is located on side of power unit.

OWNERS RECORD
Complete information at right and keep in a safe place.

Date Installed _____

Installed in Bay # _____

Power Unit Serial # _____

Power Unit Model # _____

Lift Serial # _____

Lift Model # _____

NOTE: For replacement parts -See your nearest Rotary Parts Distributor.

PB 2-70-6
Rev. -- 4-9-03

MODELS: AR55-45, AR55-51

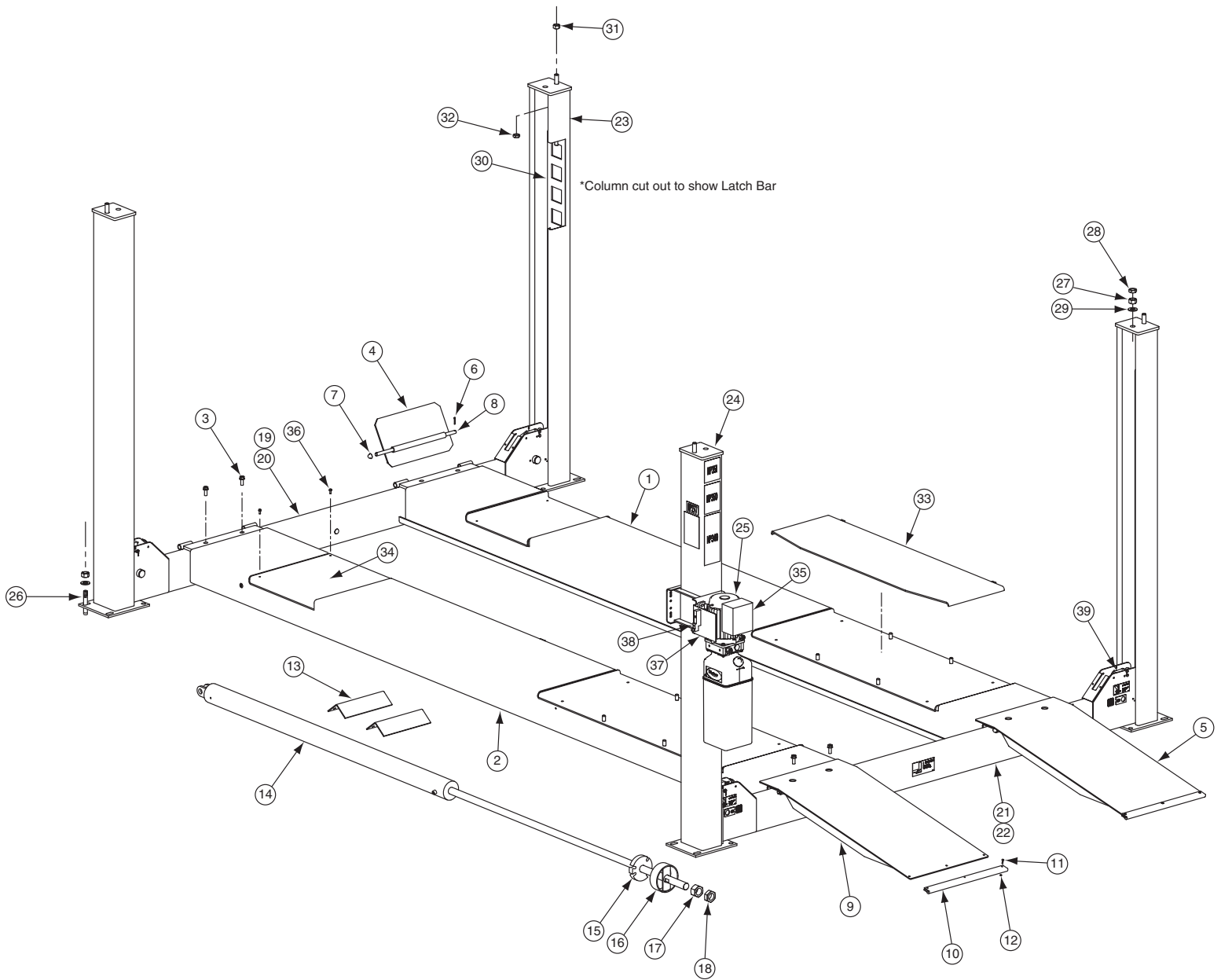

PARTS			
ITEM NO.	DESCRIPTION	PART NO.	
		AR55-45	AR55-51
1	R.H. (Adjust.) Runway Assembly	S120101	S120099
2	L.H. (Fixed) Runway Assembly (Includes cylinder, cables and sheaves)	S110107	S110108
3	1/2"- 13NC x 1 1/4", Flg. Whiz Lock HHCS (High Strength)	40279	*
4	Wheel Stop	FC134-13	*
5	Ramp Chock Assembly	S110016	*
6	5/32" x 1" Lg. Cotter Pin	41202	*
7	5/8" Push-nut Fastener — TRW #PW625019 Or Equal	FC179-4	*
8	Hinge Pin	FC134-99	*
9	Ramp Chock	S120072	*
10	Ramp Chock Slide	FC134-33	*
11	#10-24 PNHDMS x 3/4" Lg.	40050	*
12	#10-24 Hex Nut	40633	*
13	Triangular Wheel Chock	FC320	*
14	Hydraulic Cylinder	S130002	*
15	Cable Pull Bar	S120075	*
16	Cable Retaining Bar	S120068	*
17	1 3/8"-6NC Hex Nut	40771	*
18	1 3/8"-6NC Hex Jam Nut	40773	*
19	Front Yoke	S120308	*
20	Front Yoke Ass'y. (Including Latches)	S110103	*
21	Rear Yoke	S120309	*
22	Rear Yoke Ass'y. (Including Latches)	S110104	*
23	Column	S120032	*
24	Power Unit Column	S120345	*
25	Power Unit	P1165	*
26	5/8" Anchor Bolt	FC5228	*
27	7/8"-9NC Hex Nut	40765	*
28	7/8"-9NC Hex Jam Nut	40766	*
29	7/8" Flat Washer	41073	*
30	Latch Bar	S120312	*
31	3/4"-10NC Hex Jam Nut	40759	*
32	3/4"-10NC Hex Nut	40760	*
33	Rear Slip Plate Kit	FC5249	*
34	Filler Plate	FC5102	*
35	Control Box	FA7166	*
36	1/4"-20NC x 5/8" Flange Whiz-Lock HHCS Zinc Plated	42000	*
37	Air Valve Bracket	S120197	*
38	Air Valve-Electric	FA7166-2	*
39	Toe Guard Switch	S130050	*

* Part number in left column applies.

MODELS: SM55-45, SM55-51, SM40-43, SM55W51

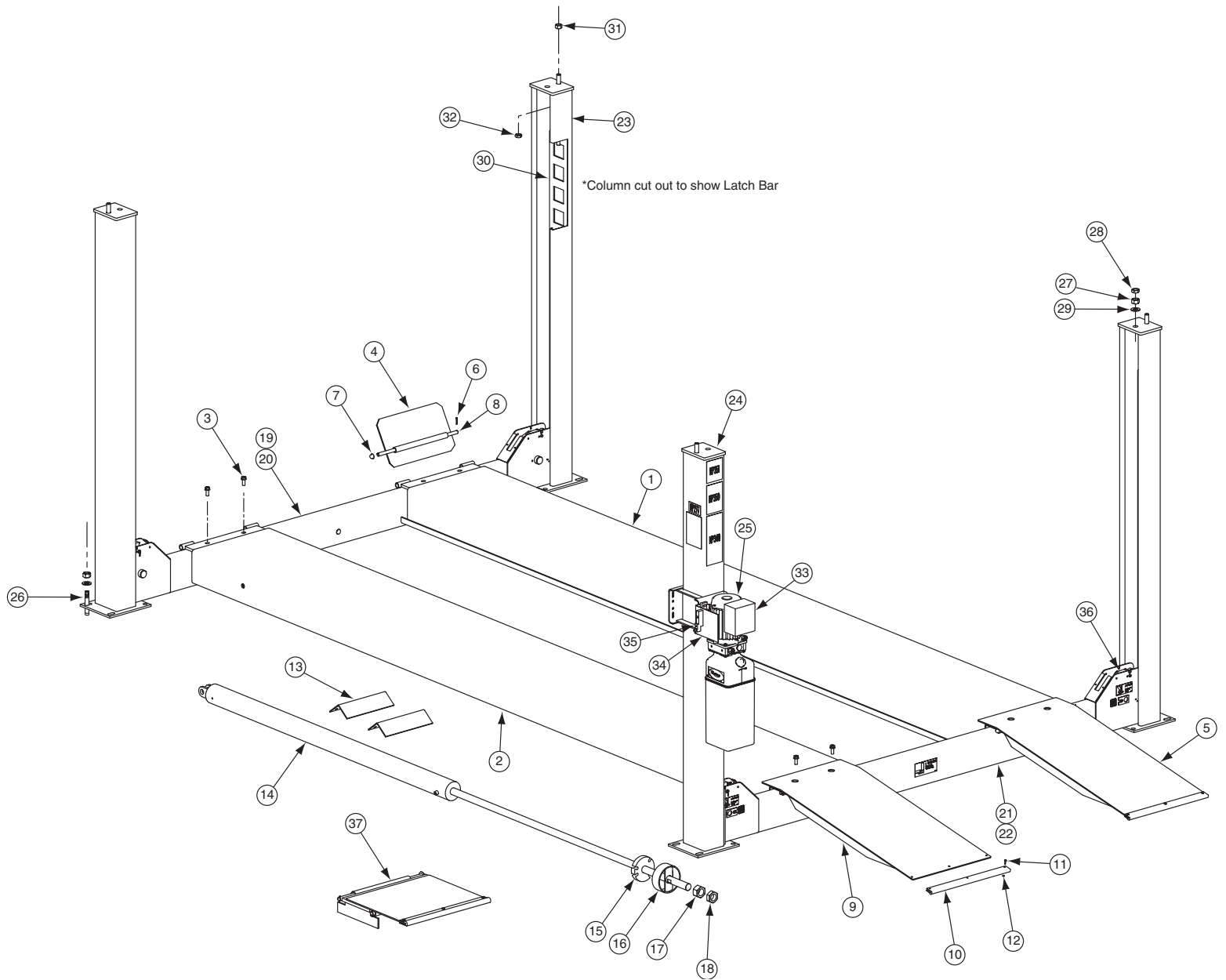

PARTS					
ITEM NO.	DESCRIPTION	PART NO.			
		SM40-43	SM55W51	SM55-45	SM55-51
1	R.H. (Adjust.) Runway Assembly	S120334	S120340	S120085	S120067
2	L.H. (Fixed) Runway Assembly (Includes cylinder, cables and sheaves)	S110117	S110109	S110105	S110106
3	1/2"-13NC x 1 1/4", Flg. Whiz Lock HHCS (High Strength)	40279	*	*	*
4	Wheel Stop	FC342	FC5804-19	*	*
5	Ramp Chock Assembly	S110016	*	*	*
6	5/32" x 1" Lg. Cotter Pin	41202	*	*	*
7	5/8" Push-nut Fastener — TRW #PW625019 Or Equal	FC179-4	*	*	*
8	Hinge Pin	FC134-99	*	*	*
9	Ramp Chock	S120072	*	*	LEFT S110090 RIGHT S110091
10	Ramp Chock Slide	FC134-33	*	*	*
11	#10-24 PNHDMS x 3/4" Lg.	40050	*	*	*
12	#10-24 Hex Nut	40633	*	*	*
13	Triangular Wheel Chock	FC320	*	*	*
14	Hydraulic Cylinder	S130002	*	*	*
15	Cable Pull Bar	S120075	*	*	*
16	Cable Retaining Bar	S120068	*	*	*
17	1 3/8"-6NC Hex Nut	40771	*	*	*
18	1 3/8"-6NC Hex Jam Nut	40773	*	*	*
19	Front Yoke	S120308	*	*	*
20	Front Yoke Ass'y. (Including Latches)	S110103	*	*	*
21	Rear Yoke	S120309	*	*	*
22	Rear Yoke Ass'y. (Including Latches)	S110104	*	*	*
23	Column	S120032	*	*	*
24	Power Unit Column	S120314	S120345	S120345	*
25	Power Unit	P1081	P1165	P1165	P1165
26	5/8" Anchor Bolt	FC5228	*	*	*
27	7/8"-9NC Hex Nut	40765	*	*	*
28	7/8"-9NC Hex Jam Nut	40766	*	*	*
29	7/8" Flat Washer	41073	*	*	*
30	Latch Bar	S120312	*	*	*
31	3/4"-10NC Hex Jam Nut	40759	*	*	*
32	3/4"-10NC Hex Nut	40760	*	*	*
33	Control Box	FA7166	*	*	*
34	Air Valve Bracket	S120197	*	*	*
35	Air Valve-Electric	FA7166-2	*	*	*
36	Toe Guard Switch	S130050	*	*	*
37	Flush Mount Ramp	FC327	*	*	*

* Part number in left column applies.

MODELS: AR40-43, AR55W51

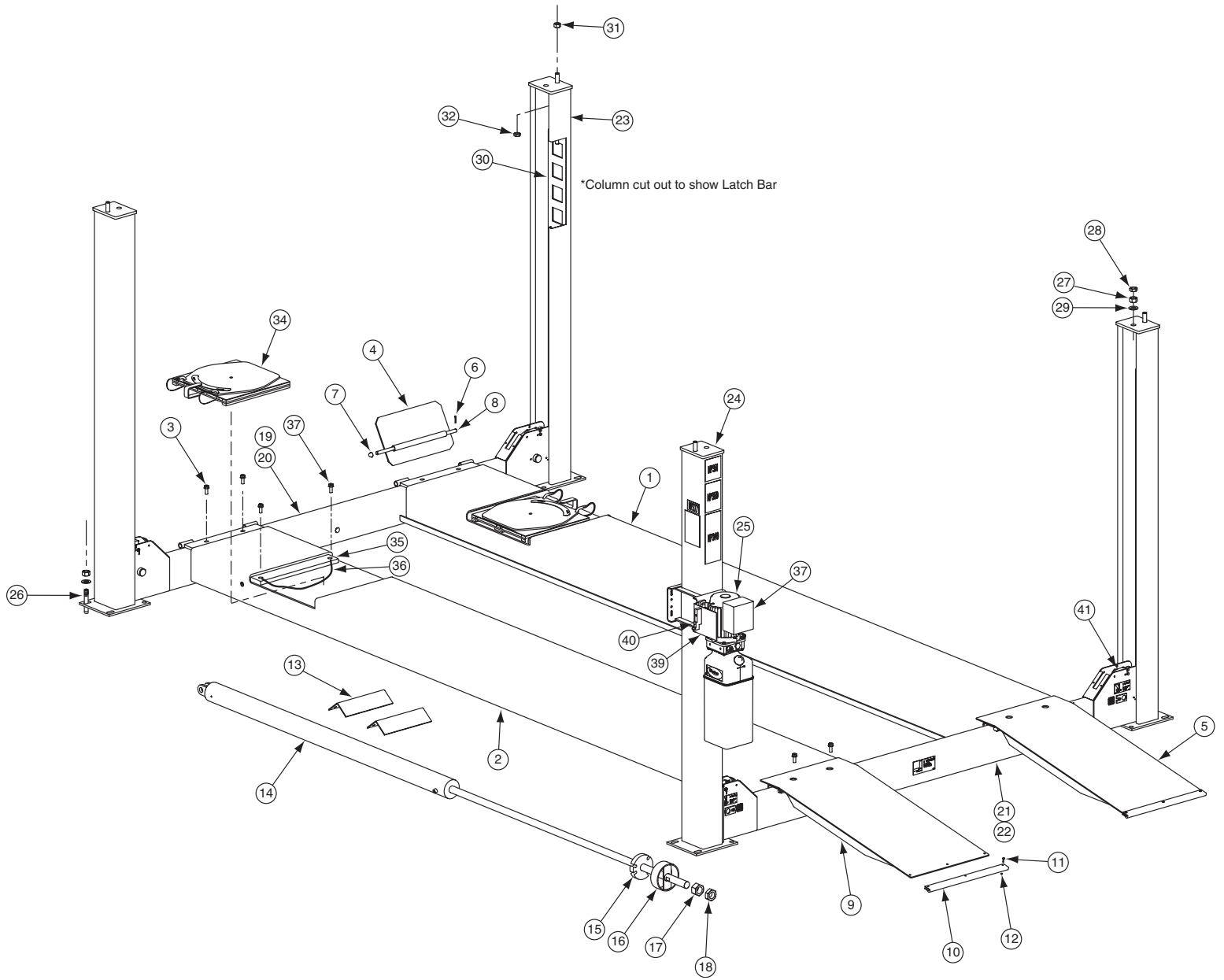

PARTS			
ITEM NO.	DESCRIPTION	PART NO.	
		AR40-43	AR55W51
1	R.H. (Adjust.) Runway Assembly	S120338	S120344
2	L.H. (Fixed) Runway Assembly (Includes cylinder, cables and sheaves)	S110119	S110110
3	1/2"- 13NC x 1 1/4", Flg. Whiz Lock HHCS (High Strength)	40279	*
4	Wheel Stop	FC5804-19	*
5	Ramp Chock Assembly	S110016	LEFT S110090 RIGHT S110091
6	5/32" x 1" Lg. Cotter Pin	41202	*
7	5/8" Push-nut Fastener — TRW #PW625019 Or Equal	FC179-4	*
8	Hinge Pin	FC134-99	*
9	Ramp Chock	S120072	*
10	Ramp Chock Slide	FC134-33	*
11	#10-24 PNHDMS x 3/4" Lg.	40050	*
12	#10-24 Hex Nut	40633	*
13	Triangular Wheel Chock	FC320	*
14	Hydraulic Cylinder	S130002	*
15	Cable Pull Bar	S120075	*
16	Cable Retaining Bar	S120068	*
17	1 3/8"-6NC Hex Nut	40771	*
18	1 3/8"-6NC Hex Jam Nut	40773	*
19	Front Yoke	S120308	*
20	Front Yoke Ass'y. (Including Latches)	S110103	*
21	Rear Yoke	S120309	*
22	Rear Yoke Ass'y. (Including Latches)	S110104	*
23	Column	S120032	*
24	Power Unit Column	S120314	S120345
25	Power Unit	P1081	P1165
26	5/8" Anchor Bolt	FC5228	*
27	7/8"-9NC Hex Nut	40765	*
28	7/8"-9NC Hex Jam Nut	40766	*
29	7/8" Flat Washer	41073	*
30	Latch Bar	S120312	*
31	3/4"-10NC Hex Jam Nut	40759	*
32	3/4"- 10NC Hex Nut	40760	*
33	Optional Flush Mount Ramp	LEFT FC329 RIGHT FC328	*
34	Turning Radius Gauge Assembly	FA5157	*
35	Turntable Guide Bar	FA5153-1	S120196
36	Retaining Cable	S130043	*
37	Control Box	FA7166	*
38	1/4"-20NC x 5/8" Flange Whiz-Lock HHCS Zinc Plated	42000	*
39	Air Valve Bracket	S120197	*
40	Air Valve-Electric	FA7166-2	*
41	Toe Guard Switch	S130050	*

* Part number in left column applies.

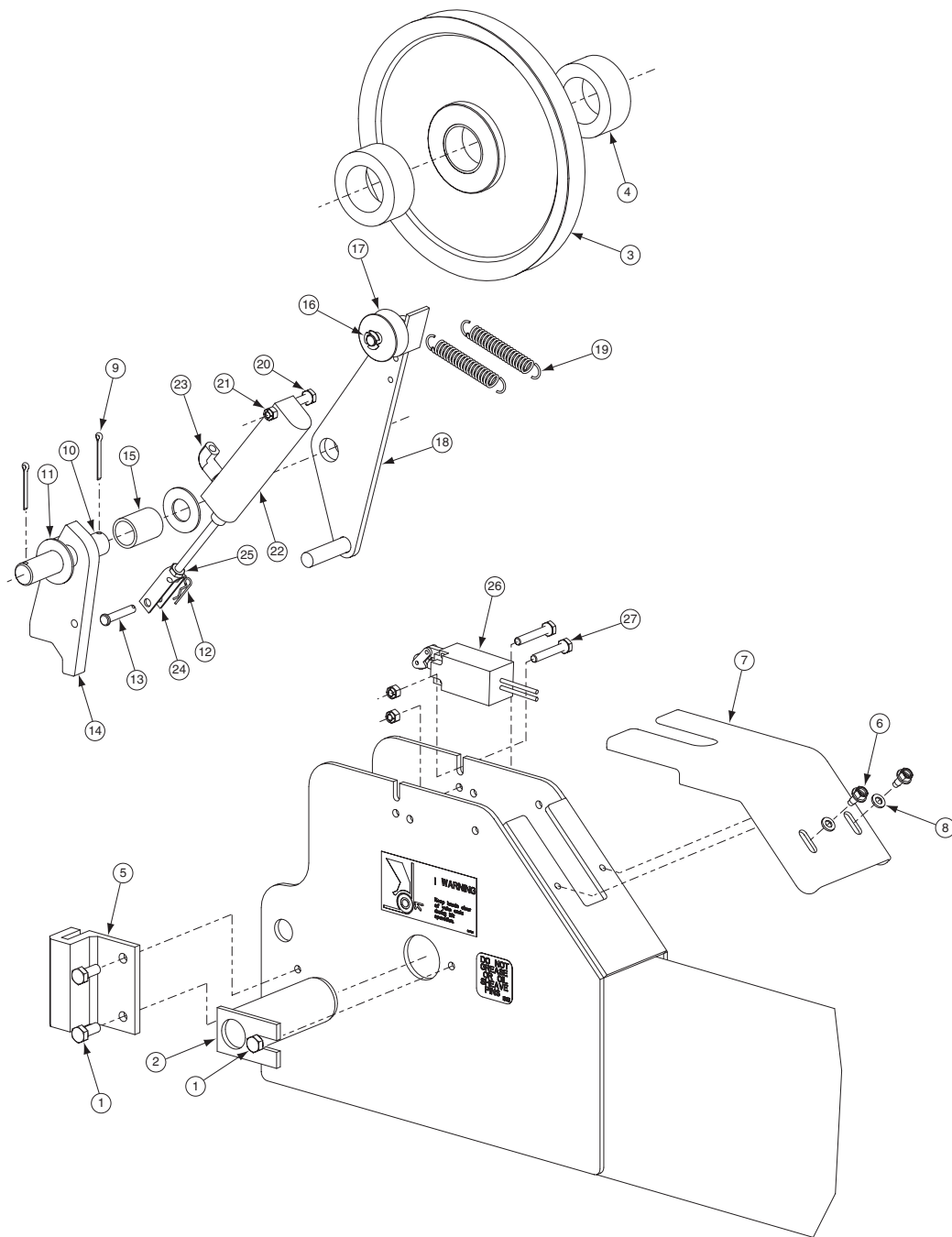

YOKE END DETAIL					
ITEM NO.	DESCRIPTION	PART NO.	ITEM NO.	DESCRIPTION	PART NO.
1	5/16"-18NC x 3/4" Lg. HHCS	40252	15	Spacer	FC5706-9
2	Sheave Pin	Standard	FC5224-21	16	3/8" Snap Ring TRUARC #5304-37
		Chrome Plated	FC5728-7	17	Slack Cable Roller
3	Sheave	FC5804-2	18	Kicker	S120178
4	Yoke Sheave Spacer	FC5927-10	19	Extension Spring	FC522-25
5	Slider	FC5706-16	20	Clevis Pin	S130051
6	1/4"-20NC HHTS x 1/2" Lg.	40067	21	1/4" Flat Washer	40782
7	Guard	FC5802-18	22	Air Cylinder	S110019
8	1/4" Plain Washer	40780			S110020
9	Cotter Pin, 1/8" x 1 1/4"	41201	23	Elbow	FC5224-39
10	Latch Shaft	FC5901-7	24	Clevis	FC5706-7
11	Washer	FC5301-98	25	1/4"-28NF Hex Nut	40622
12	1/4" Hairpin Cotter Pin (Ø.05" wire)	41901	26	Limit Switch	N411-1
13	Clevis Pin	FA2230-12	27	Bolt and Nut	2 req'd.
14	Latch	FC5706-10			

CLOSED YOKE CABLE ROUTING

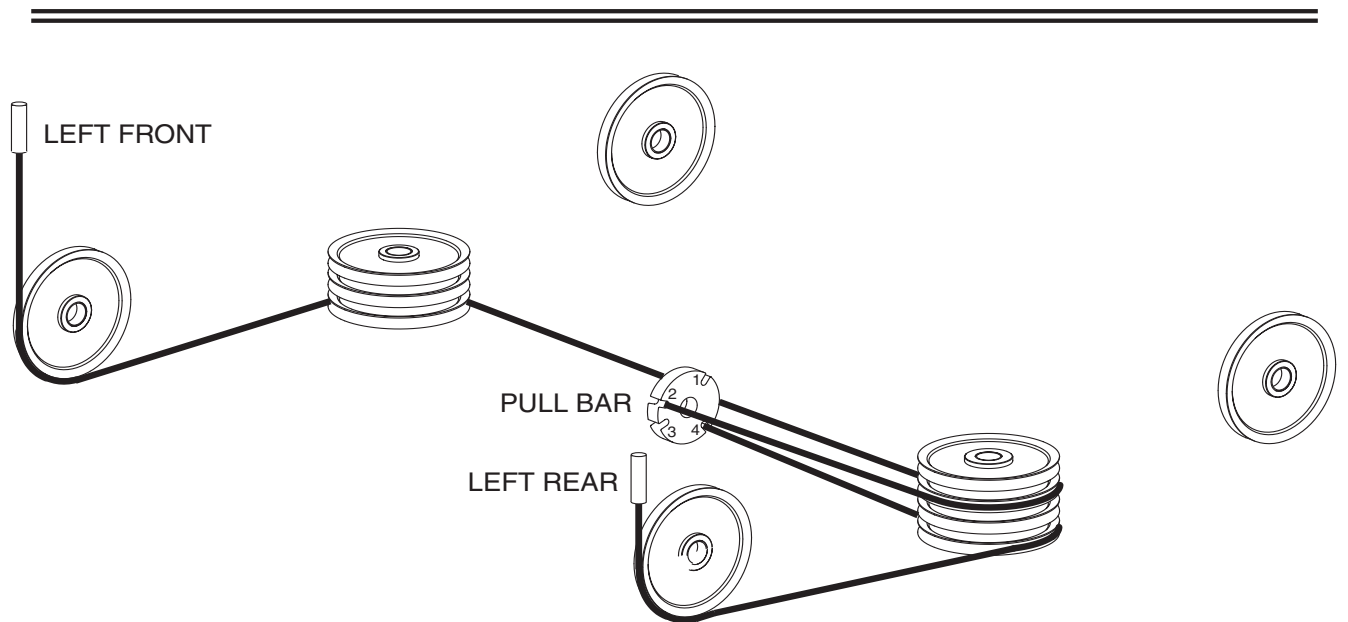
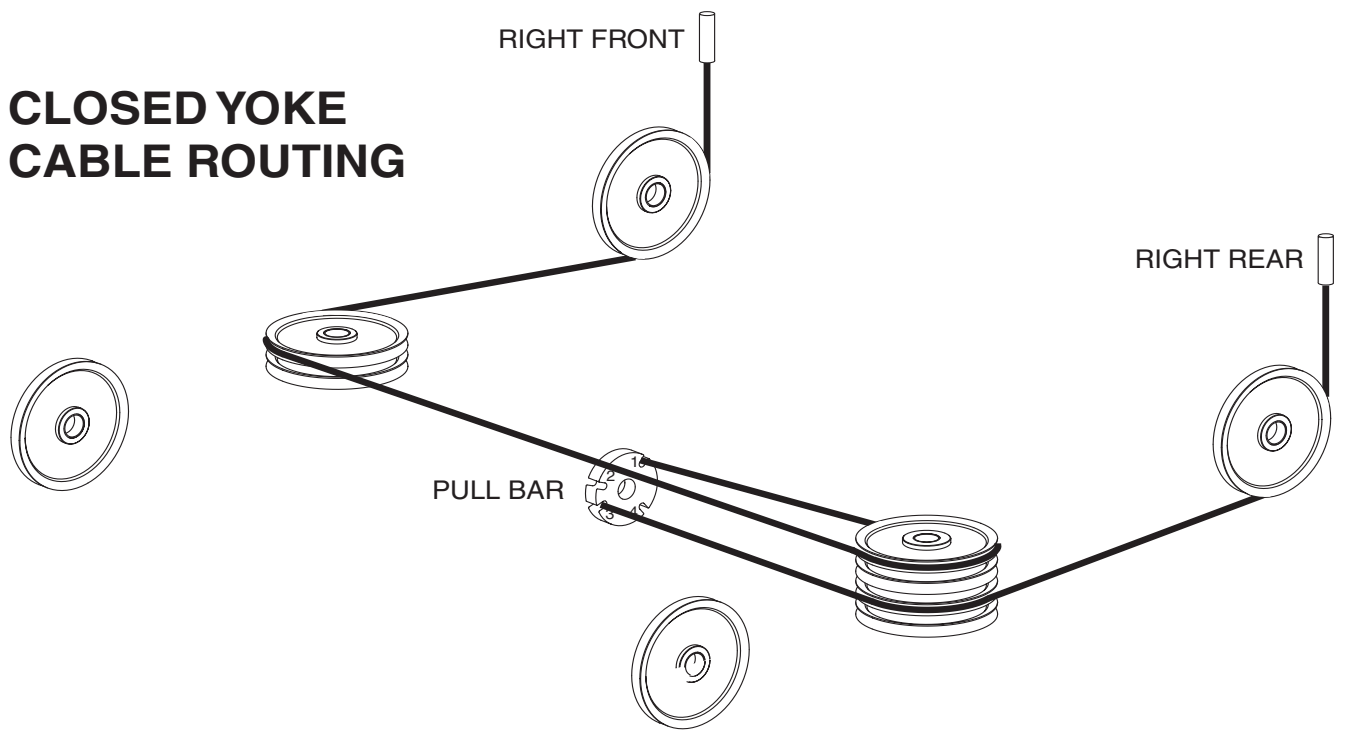

**CABLE RETAINER NOT SHOWN FOR CLARITY*

CABLES				
ITEM	DESCRIPTION	PART NO.		
		-43	-45's	-51's
1	Right Front Cable	S130079	S130075	S130076
2	Left Front Cable	S130077	S130032	S130040
3	Right Rear Cable	S130081	S130081	S130081
4	Left Rear Cable	S130038	S130038	S130038

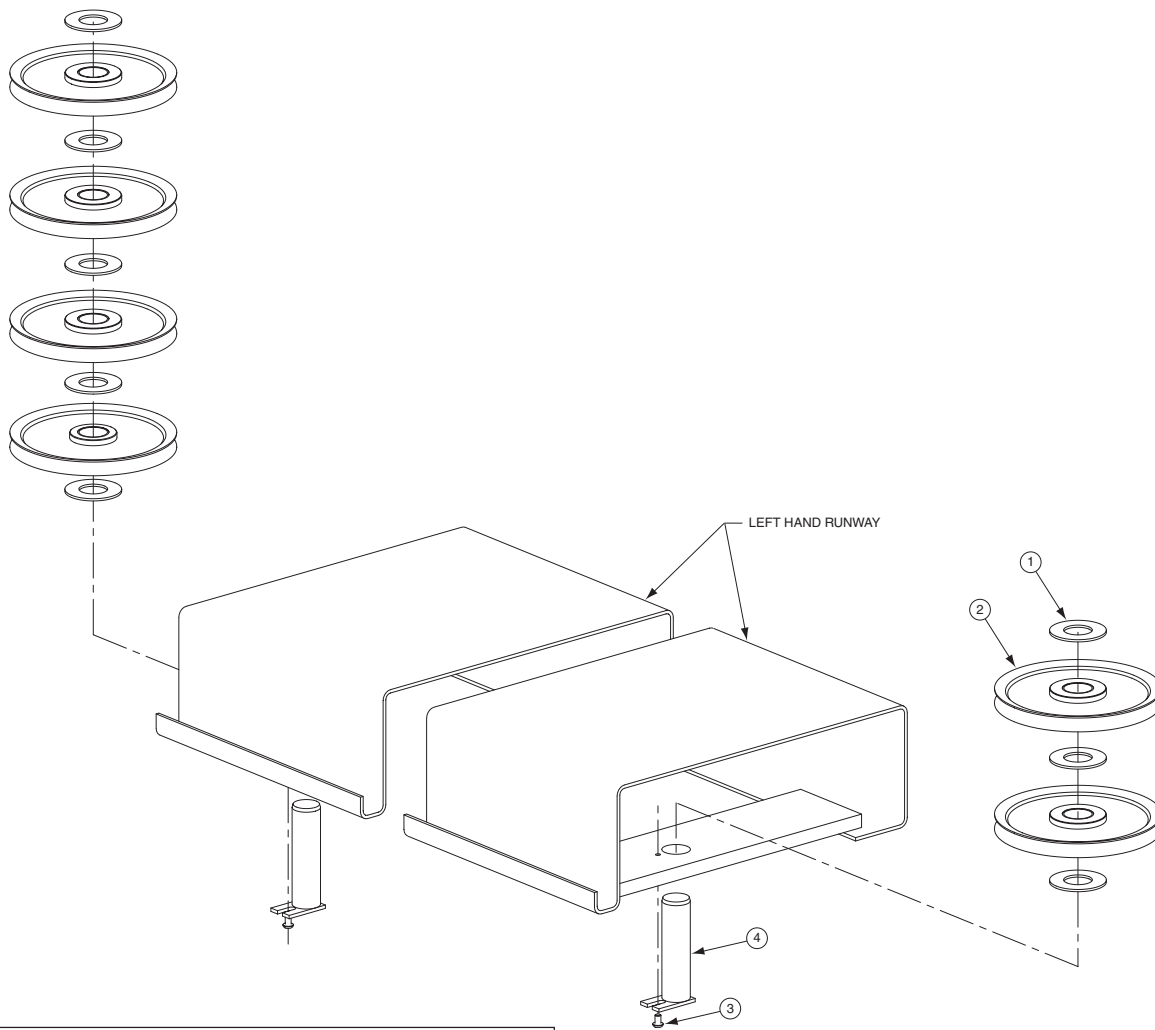

SHEAVE DETAIL		
ITEM NO.	DESCRIPTION	PART NO.
1	Sheave	FC5804-2
2	Plastic Bearing	FC5843-3
3	5/16"-18NC HSBHCS x 1/2" Lg.	40225
4	Sheave Pin	FC555-1

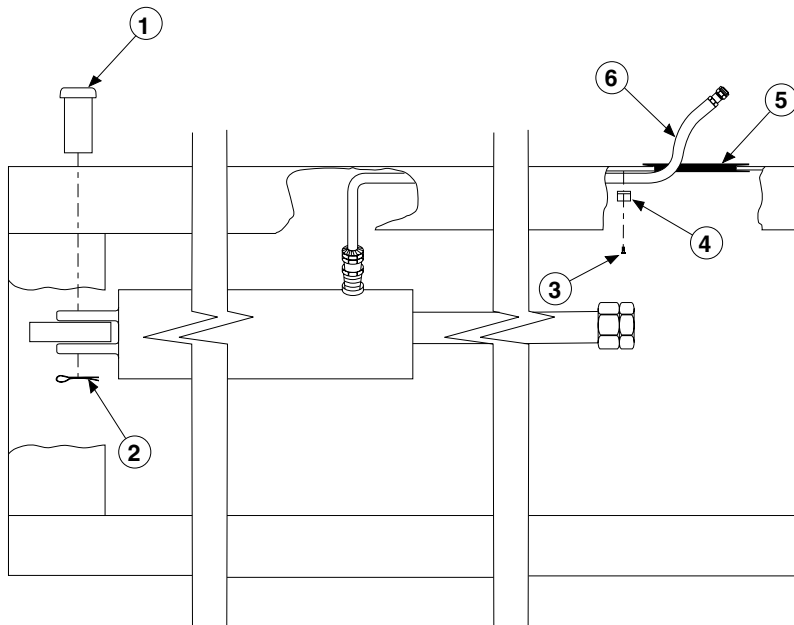

HYDRAULIC HOSE DETAIL		
ITEM NO.	DESCRIPTION	PART NO.
1	Clevis Pin	FC5346-1
2	3/16" x 1 1/4" Lg. Cotter Pin	41247
3	#10 - 24NC Slotted HHTS x 5/8" Lg.	40029
4	Clamp	FA2239-1
5	Strip Grommet	FC5317-12
6	Hose	FC5798

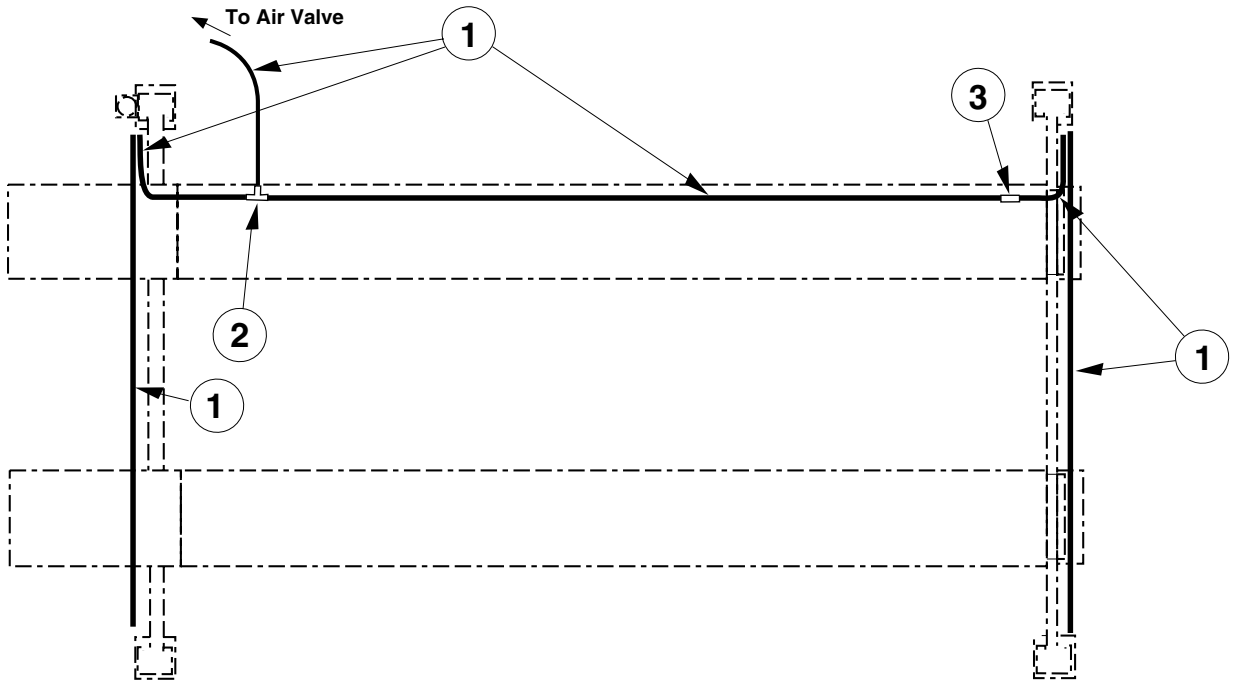

AIR LATCH AIRLINE DETAIL		
ITEM NO.	DESCRIPTION	PART NO.
1	1/4" Airline Tubing (50' roll)	FA2230-2
2	Union Tee	FC5225-46
3	Union	FC5225-98

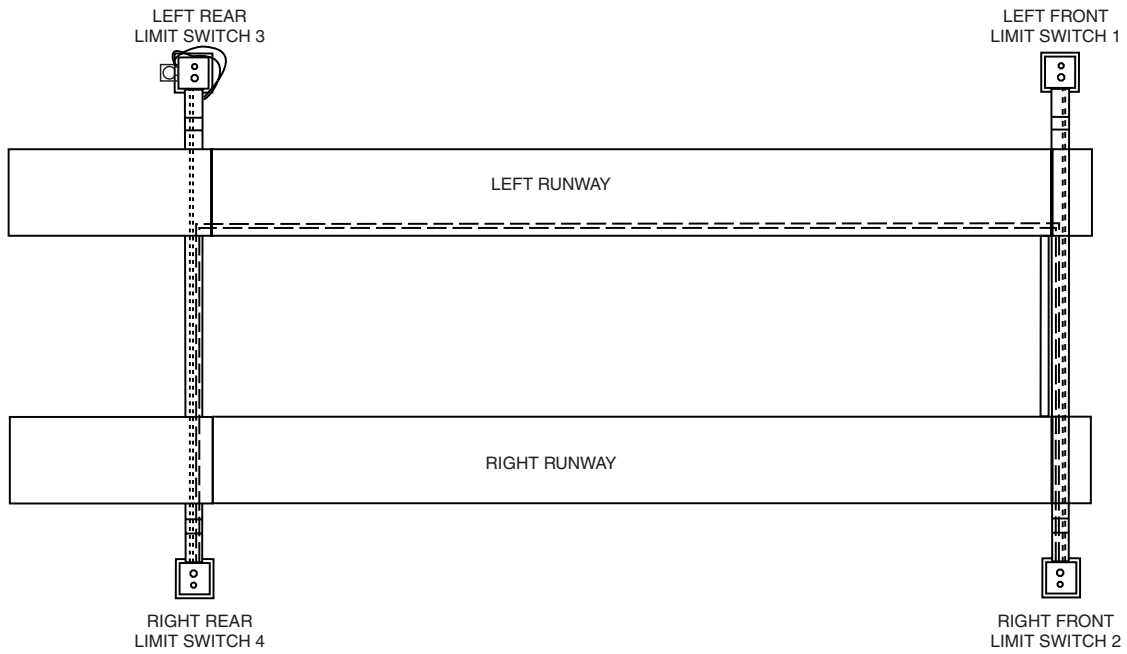

LIMIT SWITCH WIRING		
ITEM NO.	DESCRIPTION	PART NO.
1	Left Front Switch	FC5916-12
2	Right Front Switch	FC5916-13
3	Left Rear Switch	FC5888-12
4	Right Rear Switch	FC5888-13

World Headquarters:
Rotary Lift
A **DOVER** COMPANY
2700 Lanier Drive
Madison, Indiana USA
Phone: 1.800.445.5438
Phone: 1.812.273.1622
Fax: 1.800.578.5438
Fax: 1.812.273.6502
userlink@rotarylif.com
www.rotarylif.com

Italy:
(Regional Sales Office)
Rotary Lift Europe S.r.l.
Cadriano (BO)
Phone: +39.051.763384
Fax: +39.051.763395
info@rotaryeurope.com

Germany:
(European Sales Headquarters)
Rotary Lift Germany GmbH
Bensheim
Phone: +49.6251.582.6420
Fax: +49.6251.582.6422
sales@rotarylif.de

United Kingdom:
(Regional Sales Office)
Rotary Lift (UK) LTD.
Halstead, Essex
Phone: +44.178.747.7711
Fax: +44.178.747.7720
sales@rotarylif.idps.co.uk

Canada:
(Regional Sales Office)
Rotary Lift Canada
Mississauga, Ontario
Phone: 905.812.9920
Fax: 905.812.9719
canada@rotarylif.com

Austral-Asia:
(Regional Sales Office)
Rotary Lift Austral/Asia
Petaling Jaya, Malaysia
Phone: +60.3.7660.0285
Fax: +60.3.7660.0289
rlim@rotarylif.com

