

LISTA COMPONENTI
LIST OF COMPONENTS
LISTE DE COMPOSANTS
ERSATZTEILLISTE
LISTA DE LOS COMPONENTES

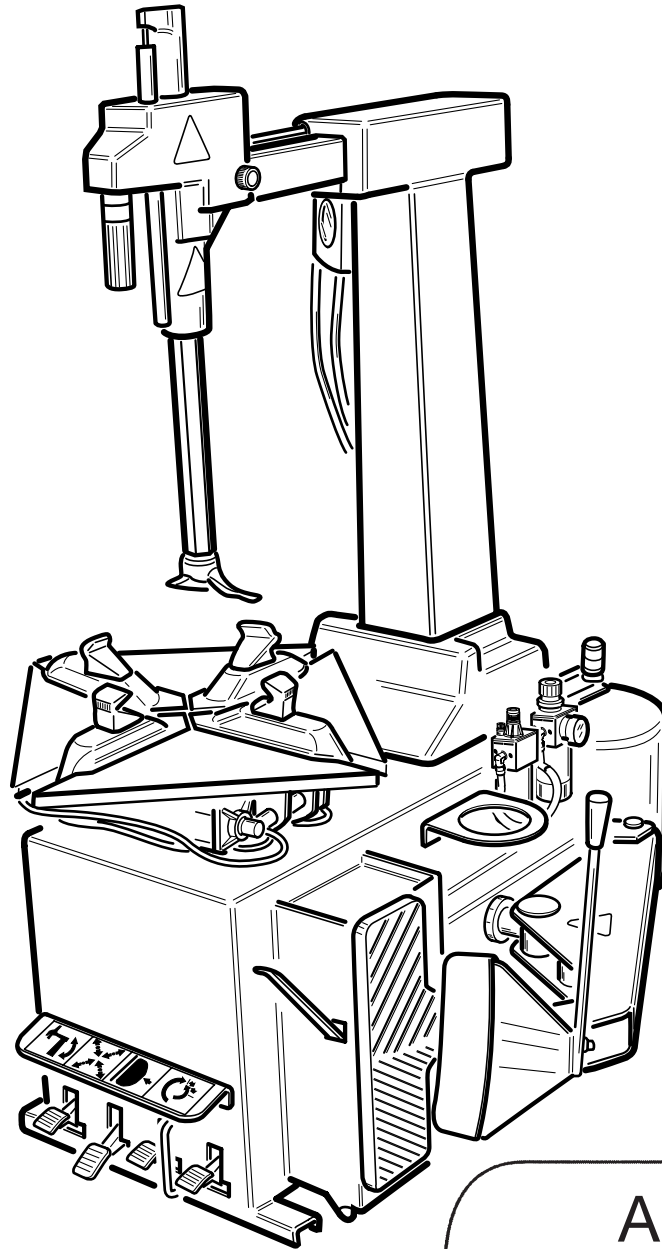

AS 944
AS 944 T.I.
AS 944 SJ T.I.

4-104325A - 0607

ISTRUZIONI PER LA RICHIESTA DEI RICAMBI

- 1) Consultando le tavole di seguito riportate, individuare esattamente il n. del particolare desiderato (Ex. Tav. A n. A1).
- 2) Dalla tabella ricambi, trovare il corrispondente codice (Ex. 9004-102137)
- 3) Nella richiesta specificare esattamente:
Il modello ed il n. di matricola della macchina.
Il codice ricambio del particolare desiderato.
Ex. As944 matr. 100, cod. 9004-102137.

INSTRUCTIONS FOR REQUESTING SPARE PARTS

- 1) Consulting the following tables, single out the exact n. of spare parts requested (Eg. Table A n. A1).
- 2) Find the corresponding spare parts code from the spare parts table (E. 9004-102137)
- 3) In the request specify exactly:
The model and serial n. of the machine.
The spare parts code of the requested spare part.
Eg. As944 matr. 100, cod. 9004-102137.

INSTRUCTIONS POUR LA DEMANDE DE PIÈCES DE RECHANGE

- 1) En consultant les tables ci-après, individualiser exactement le n. du détail désiré (Ex. Table A n. A1).
- 2) De la table des pièces de rechange, trouver le code correspondant (Ex. 9004-102137)
- 3) Dans la demande spécifier exactement:
Le modèle et le n. de matricule de la machine.
Le code pièce de rechange du détail désiré.
Ex. As944 matr. 100, cod. 9004-102137.

ANWEISUNG FÜR DIE ERSATZTEILANFORDERUNG

- 1) Bestimmen Sie genau anhand der nach stehend angeführten Übersichtstafeln die Nummer des gewünschten Teils (z.B. Tav. A Nr. A1).
- 2) Aus der Ersatzteiltafel den entsprechenden Code aufnoieren Z.B. 9004-102137.
- 3) Bezeichnen Sie in der Anforderung klar und präzise:
Das Model und die Maschinennummer.
Den Ersatzteilcode des gewünschten Teils.
Z.B. As944 matr. 100, cod. 9004-102137.

INSTRUCCIONES PARA EL PEDIDO DE REPUESTOS

- 1) Consultando las tablas detalladas a continuación, identificar exactamente el n° de las piezas que se desean pedir (Ej. Tav. A n. A1).
- 2) Partiendo de la tabla, encontrar el código correspondiente (ej.: 9004-102137)
- 3) En el pedido especificar exactamente:
El modelo y el n° de la matricola de la máquina.
El código del repuesto de la pieza deseada.
Ej. As944 matr. 100, cod. 9004-102137.

IMPORTANTE: per la richiesta dei ricambi far riferimento al codice ricambi (vedi pag. 19hhh).
IMPORTANT: for the request of spare parts please refer to spare parts code (see page 19).
IMPORTANT: pour la demande de pièces de rechange faire référence au code des pièces de rechange (voir pages 19).
WICHTIG: für die Anforderung von Ersatzteilen die Ersatzteilcodes (siehe Seite 19) angeben.
IMPORTANTE: para pedir los repuestos remitirse al código repuestos (ver pag. 19).

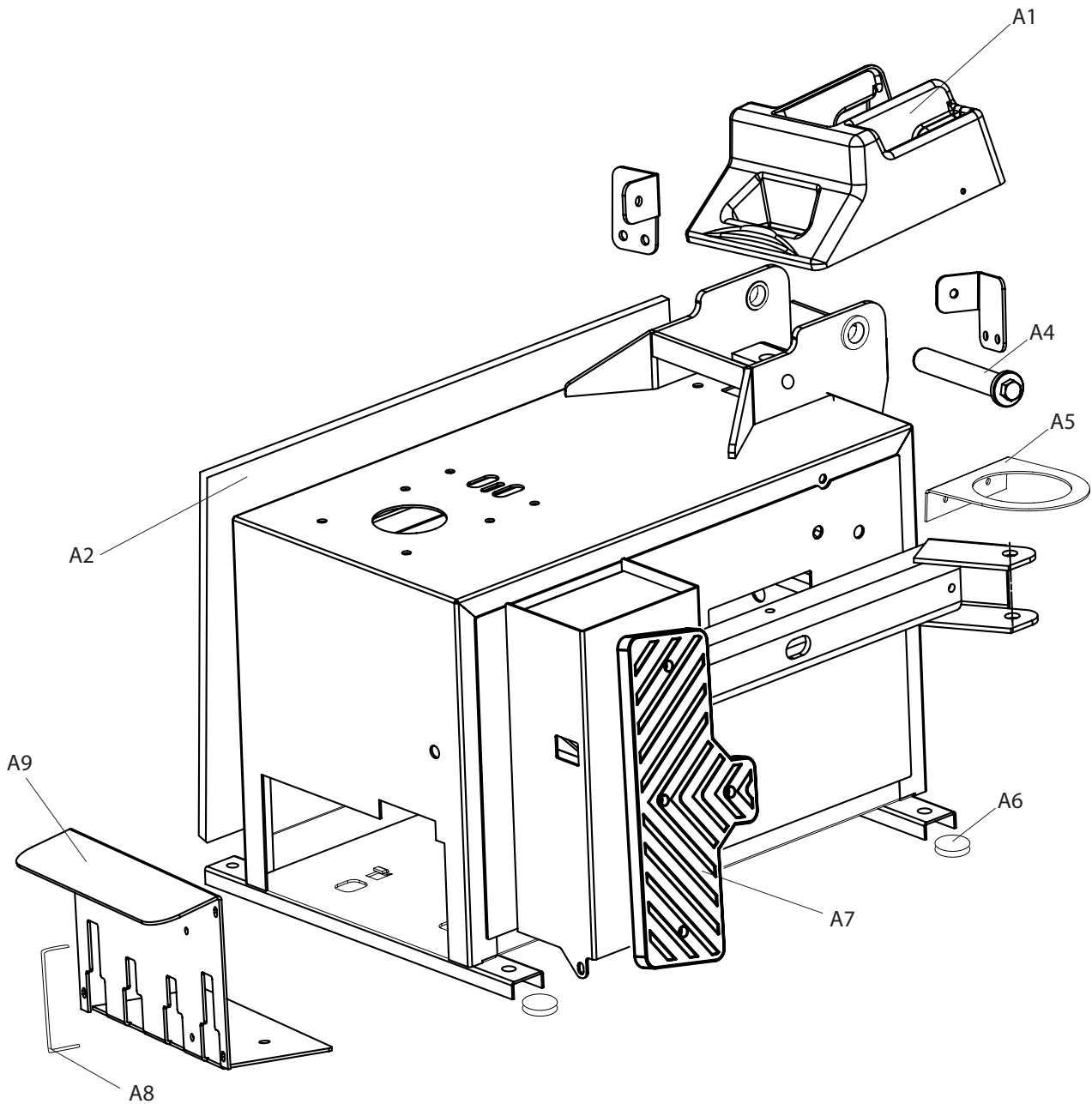

IMPORTANTE: per la richiesta dei ricambi far riferimento al codice ricambi (vedi pag. 19).
IMPORTANT: for the request of spare parts please refer to spare parts code (see page 19).
IMPORTANT: pour la demande de pièces de rechange faire référence au code des pièces de rechange (voir pages 19).
WICHTIG: für die Anforderung von Ersatzteilen die Ersatzteilcodes (siehe Seite 19) angeben.
IMPORTANTE: para pedir los repuestos remitirse al código repuestos (ver pag. 19).

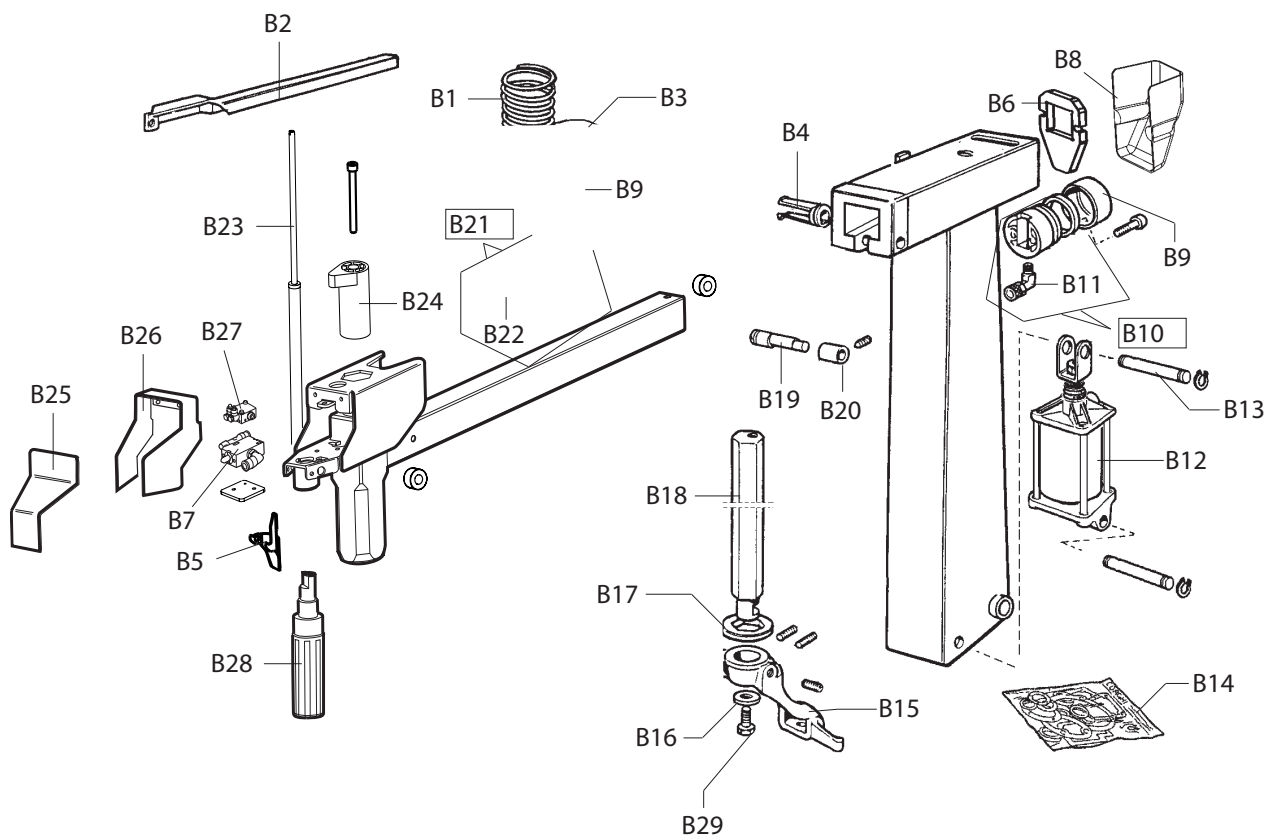

IMPORTANTE: per la richiesta dei ricambi far riferimento al codice ricambi (vedi pag. 19).
IMPORTANT: for the request of spare parts please refer to spare parts code (see page 19).
IMPORTANT: pour la demande de pièces de rechange faire référence au code des pièces de rechange (voir pages 19).
WICHTIG: für die Anforderung von Ersatzteilen die Ersatzteilcodes (siehe Seite 19) angeben.
IMPORTANTE: para pedir los repuestos remitirse al código repuestos (ver pag. 19).

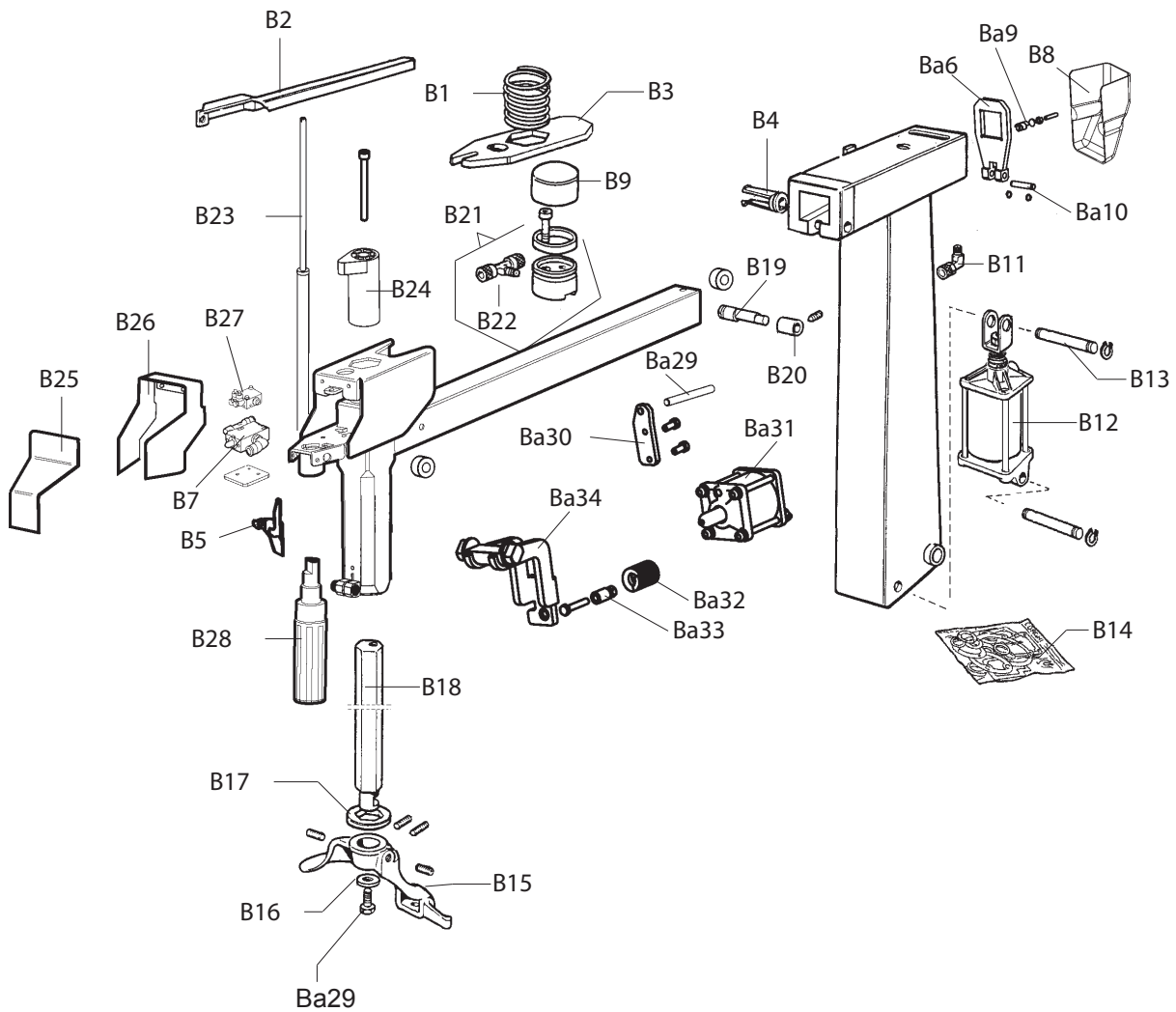

IMPORTANTE: per la richiesta dei ricambi far riferimento al codice ricambi (vedi pag. 20).
IMPORTANT: for the request of spare parts please refer to spare parts code (see page 20).
IMPORTANT: pour la demande de pièces de rechange faire référence au code des pièces de rechange (voir pages 20).
WICHTIG: für die Anforderung von Ersatzteilen die Ersatzteilcodes (siehe Seite 20) angeben.
IMPORTANTE: para pedir los repuestos remitirse al código repuestos (ver pag. 20).

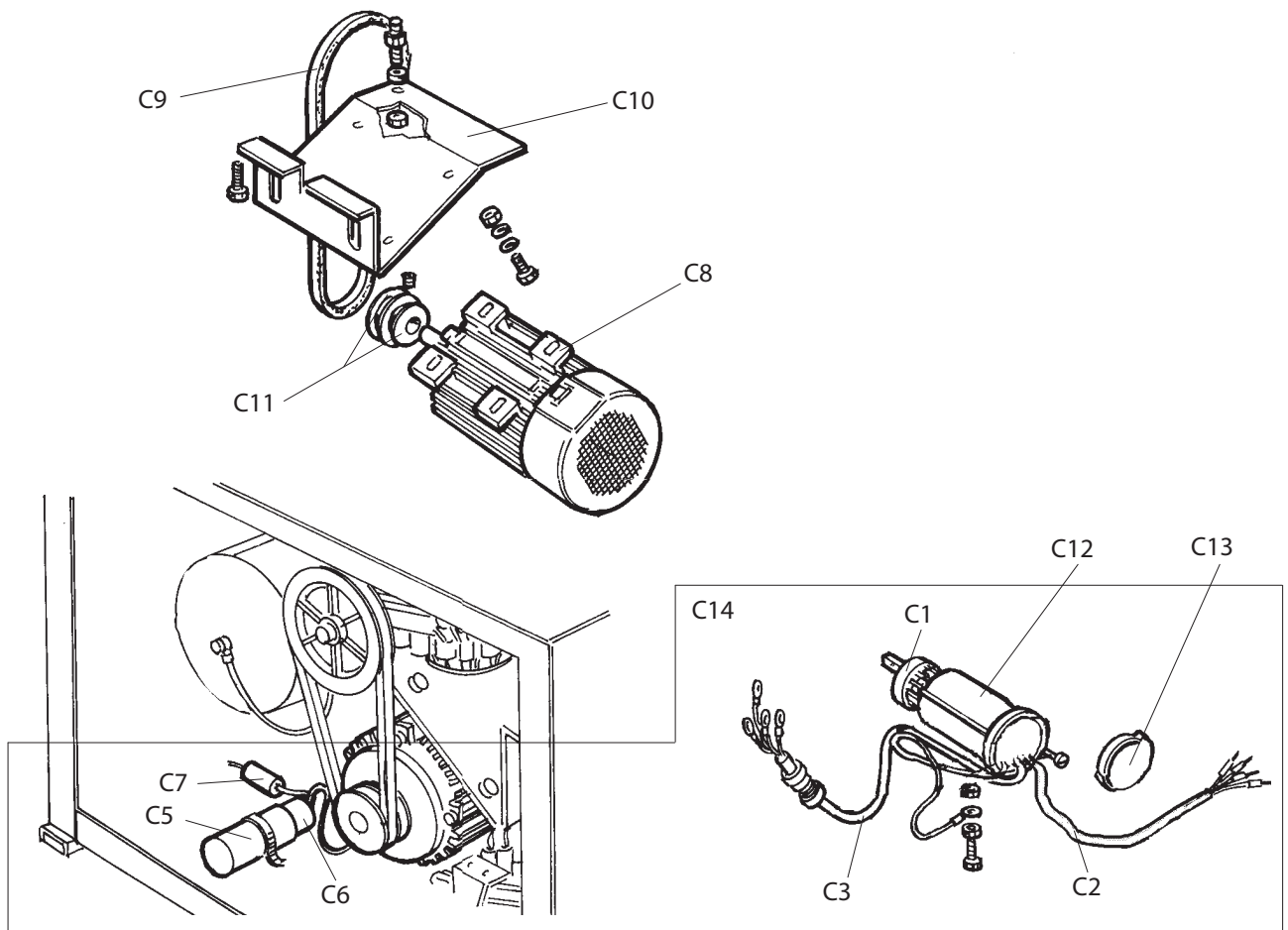

IMPORTANTE: per la richiesta dei ricambi far riferimento al codice ricambi (vedi pag. 21).
IMPORTANT: for the request of spare parts please refer to spare parts code (see page 21).
IMPORTANT: pour la demande de pièces de rechange faire référence au code des pièces de rechange (voir pages 21).
WICHTIG: für die Anforderung von Ersatzteilen die Ersatzteilcodes (siehe Seite 21) angeben.
IMPORTANTE: para pedir los repuestos remitirse al código repuestos (ver pag. 21).

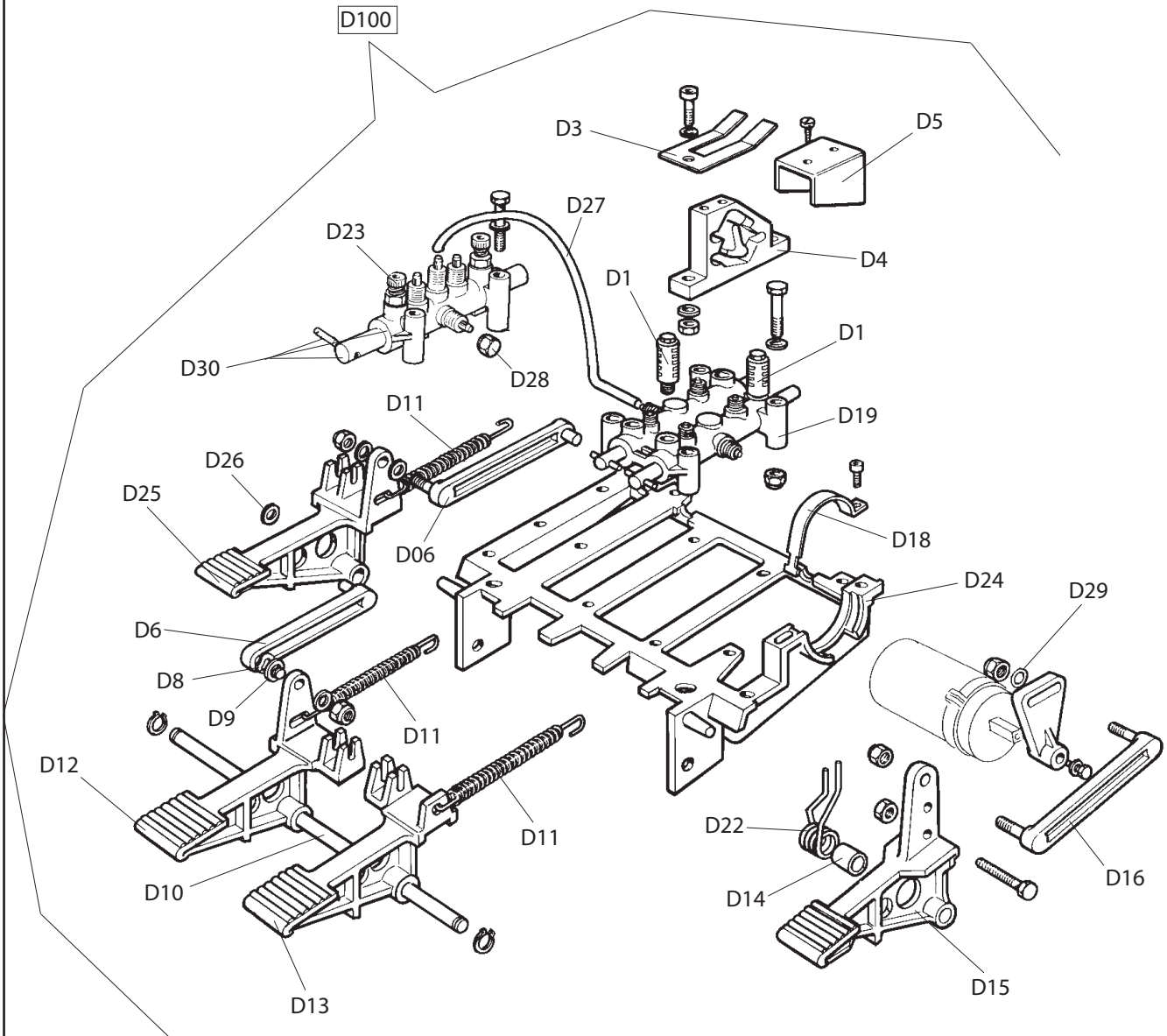

IMPORTANTE: per la richiesta dei ricambi far riferimento al codice ricambi (vedi pag. 22).
IMPORTANT: for the request of spare parts please refer to spare parts code (see page 22).
IMPORTANT: pour la demande de pièces de rechange faire référence au code des pièces de rechange (voir pages 22).
WICHTIG: für die Anforderung von Ersatzteilen die Ersatzteilcodes (siehe Seite 22) angeben.
IMPORTANTE: para pedir los repuestos remitirse al código repuestos (ver pag. 22).

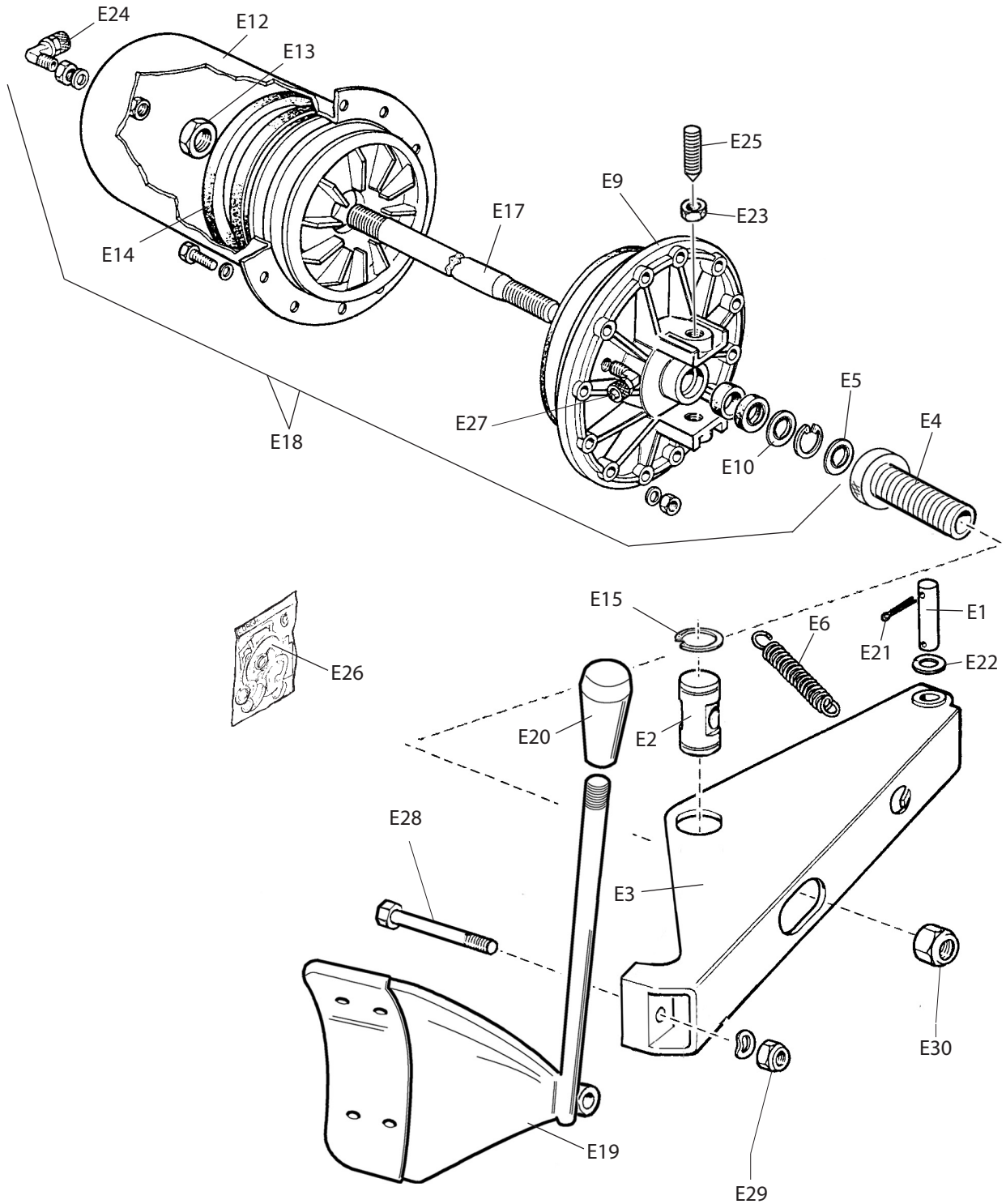

IMPORTANTE: per la richiesta dei ricambi far riferimento al codice ricambi (vedi pag. 22).
IMPORTANT: for the request of spare parts please refer to spare parts code (see page 22).
IMPORTANT: pour la demande de pièces de rechange faire référence au code des pièces de rechange (voir pages 22).
WICHTIG: für die Anforderung von Ersatzteilen die Ersatzteilcodes (siehe Seite 22) angeben.
IMPORTANTE: para pedir los repuestos remitirse al código repuestos (ver pag. 22).

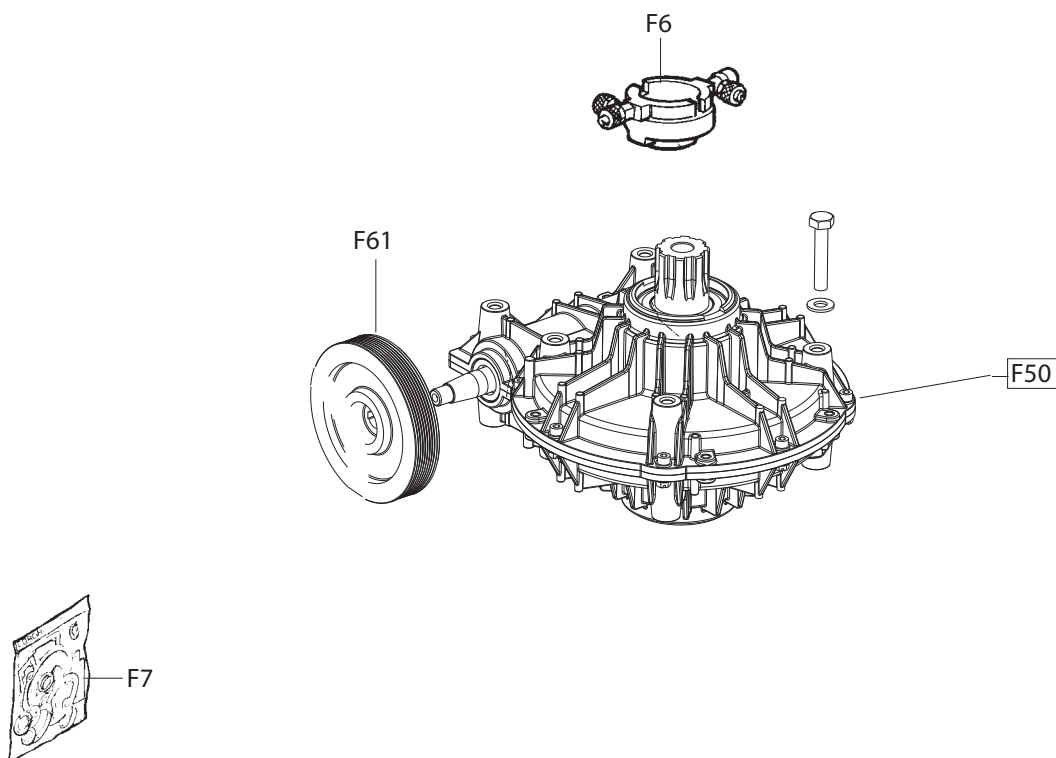

IMPORTANTE: per la richiesta dei ricambi far riferimento al codice ricambi (vedi pag. 23).
IMPORTANT: for the request of spare parts please refer to spare parts code (see page 23).
IMPORTANT: pour la demande de pièces de rechange faire référence au code des pièces de rechange (voir pages 23).
WICHTIG: für die Anforderung von Ersatzteilen die Ersatzteilcodes (siehe Seite 23) angeben.
IMPORTANTE: para pedir los repuestos remitirse al código repuestos (ver pag. 23).

G3

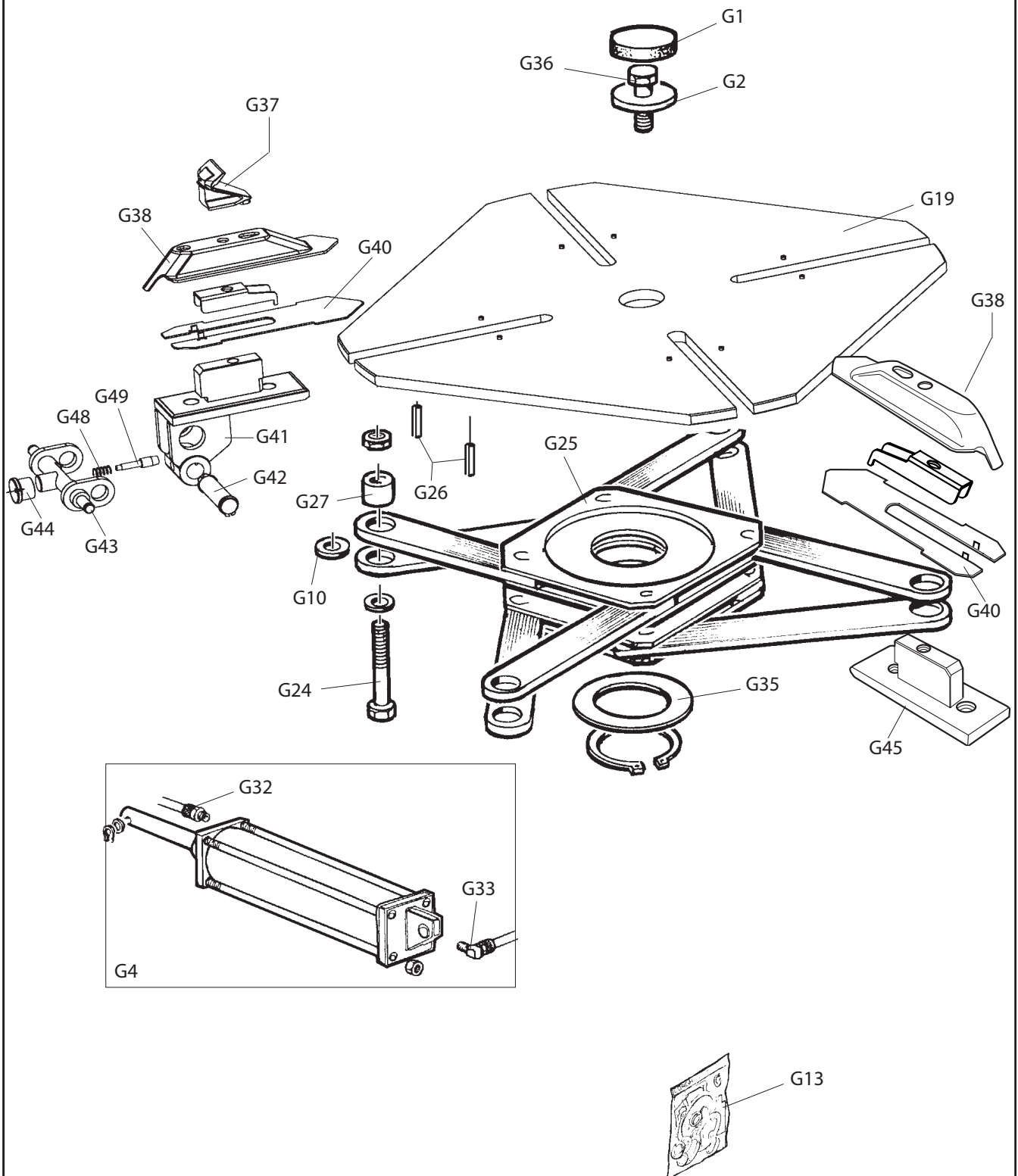

IMPORTANTE: per la richiesta dei ricambi far riferimento al codice ricambi (vedi pag. 23).
IMPORTANT: for the request of spare parts please refer to spare parts code (see page 23).
IMPORTANT: pour la demande de pièces de rechange faire référence au code des pièces de rechange (voir pages 23).
WICHTIG: für die Anforderung von Ersatzteilen die Ersatzteilcodes (siehe Seite 23) angeben.
IMPORTANTE: para pedir los repuestos remitirse al código repuestos (ver pag. 23).

H3

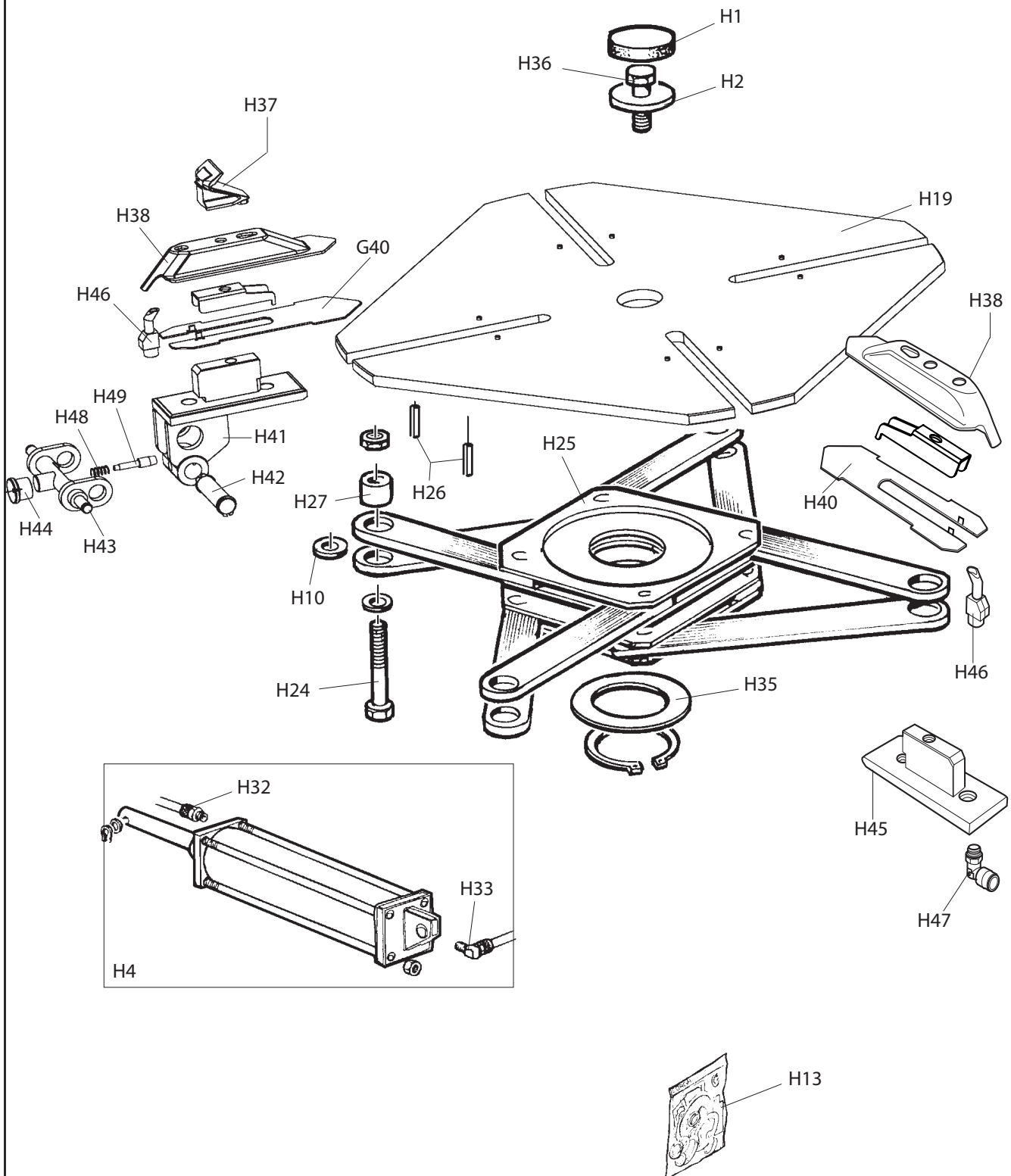

IMPORTANTE: per la richiesta dei ricambi far riferimento al codice ricambi (vedi pag. 24).
IMPORTANT: for the request of spare parts please refer to spare parts code (see page 24).
IMPORTANT: pour la demande de pièces de rechange faire référence au code des pièces de rechange (voir pages 24).
WICHTIG: für die Anforderung von Ersatzteilen die Ersatzteilcodes (siehe Seite 24) angeben.
IMPORTANTE: para pedir los repuestos remitirse al código repuestos (ver pag. 24).

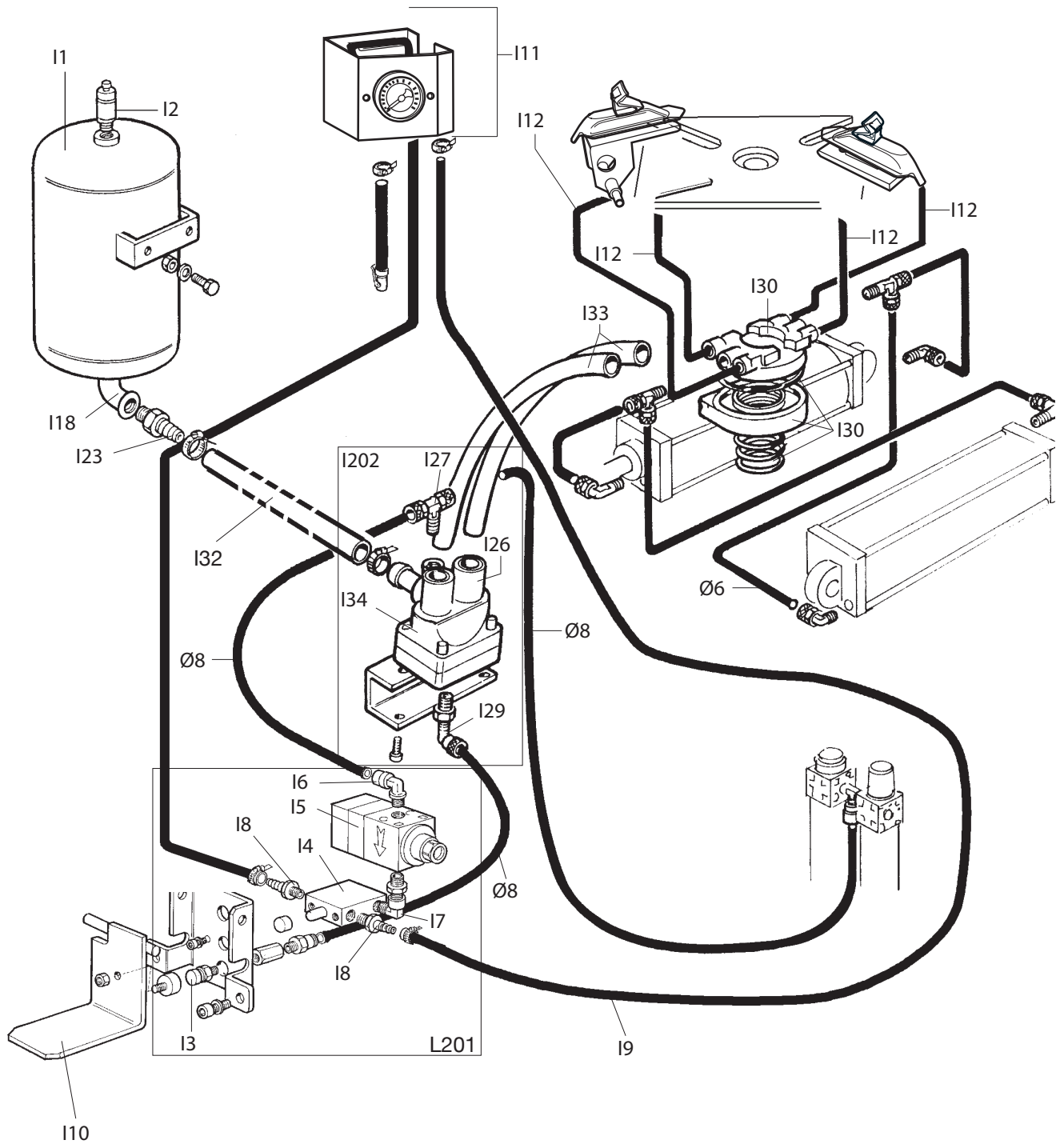

IMPORTANTE: per la richiesta dei ricambi far riferimento al codice ricambi (vedi pag. 24).
IMPORTANT: for the request of spare parts please refer to spare parts code (see page 24).
IMPORTANT: pour la demande de pièces de rechange faire référence au code des pièces de rechange (voir pages 24).
WICHTIG: für die Anforderung von Ersatzteilen die Ersatzteilcodes (siehe Seite 24) angeben.
IMPORTANTE: para pedir los repuestos remitirse al código repuestos (ver pag. 24).

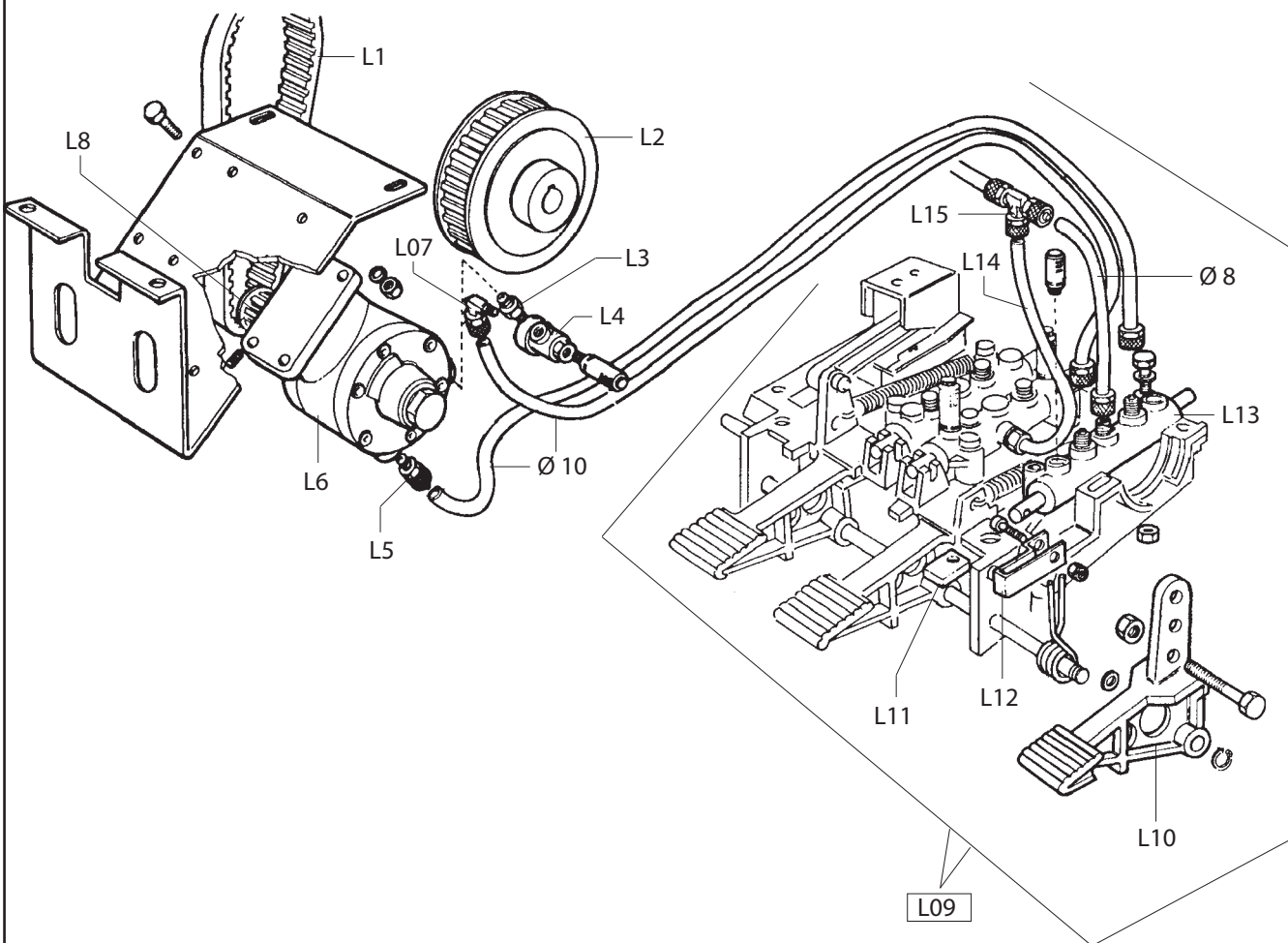

IMPORTANTE: per la richiesta dei ricambi far riferimento al codice ricambi (vedi pag. 25).
IMPORTANT: for the request of spare parts please refer to spare parts code (see page 25).
IMPORTANT: pour la demande de pièces de rechange faire référence au code des pièces de rechange (voir pages 25).
WICHTIG: für die Anforderung von Ersatzteilen die Ersatzteilcodes (siehe Seite 25) angeben.
IMPORTANTE: para pedir los repuestos remitirse al código repuestos (ver pag. 25).

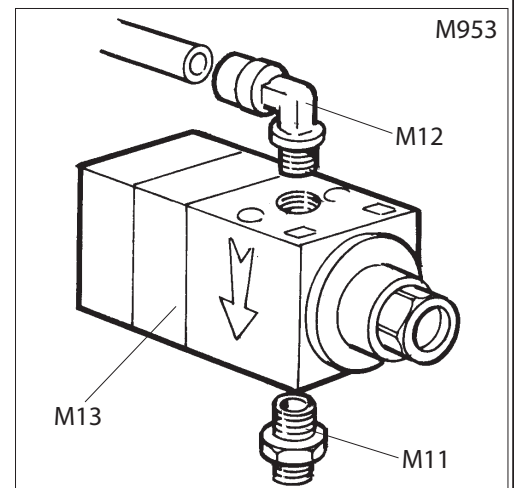
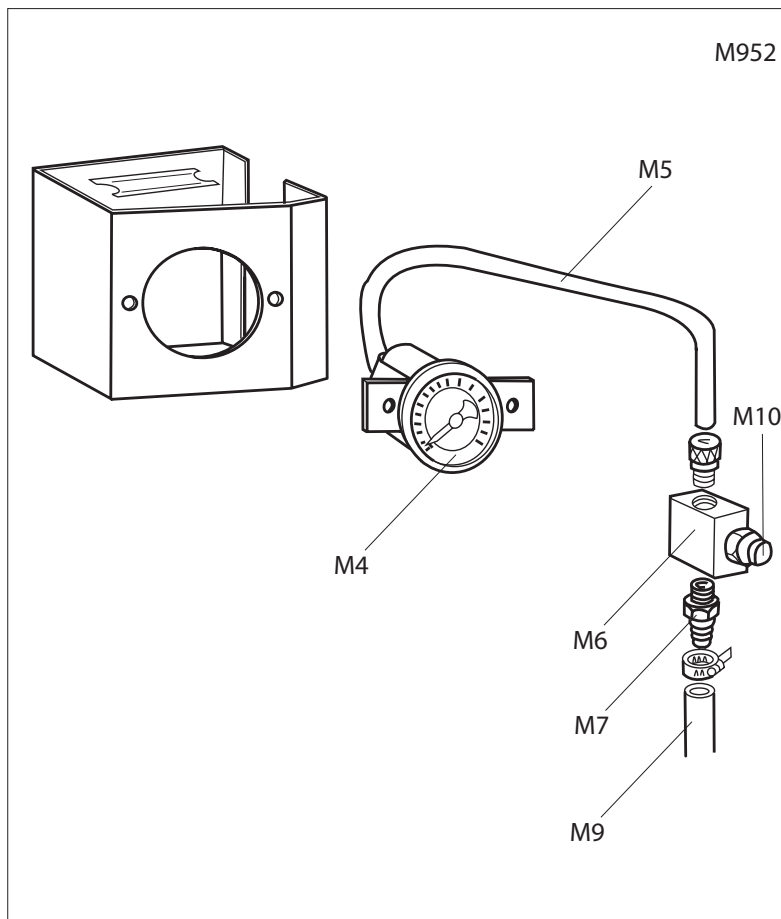

IMPORTANTE: per la richiesta dei ricambi far riferimento al codice ricambi (vedi pag. 25).
IMPORTANT: for the request of spare parts please refer to spare parts code (see page 25).
IMPORTANT: pour la demande de pièces de rechange faire référence au code des pièces de rechange (voir pages 25).
WICHTIG: für die Anforderung von Ersatzteilen die Ersatzteilcodes (siehe Seite 25) angeben.
IMPORTANTE: para pedir los repuestos remitirse al código repuestos (ver pag. 25).

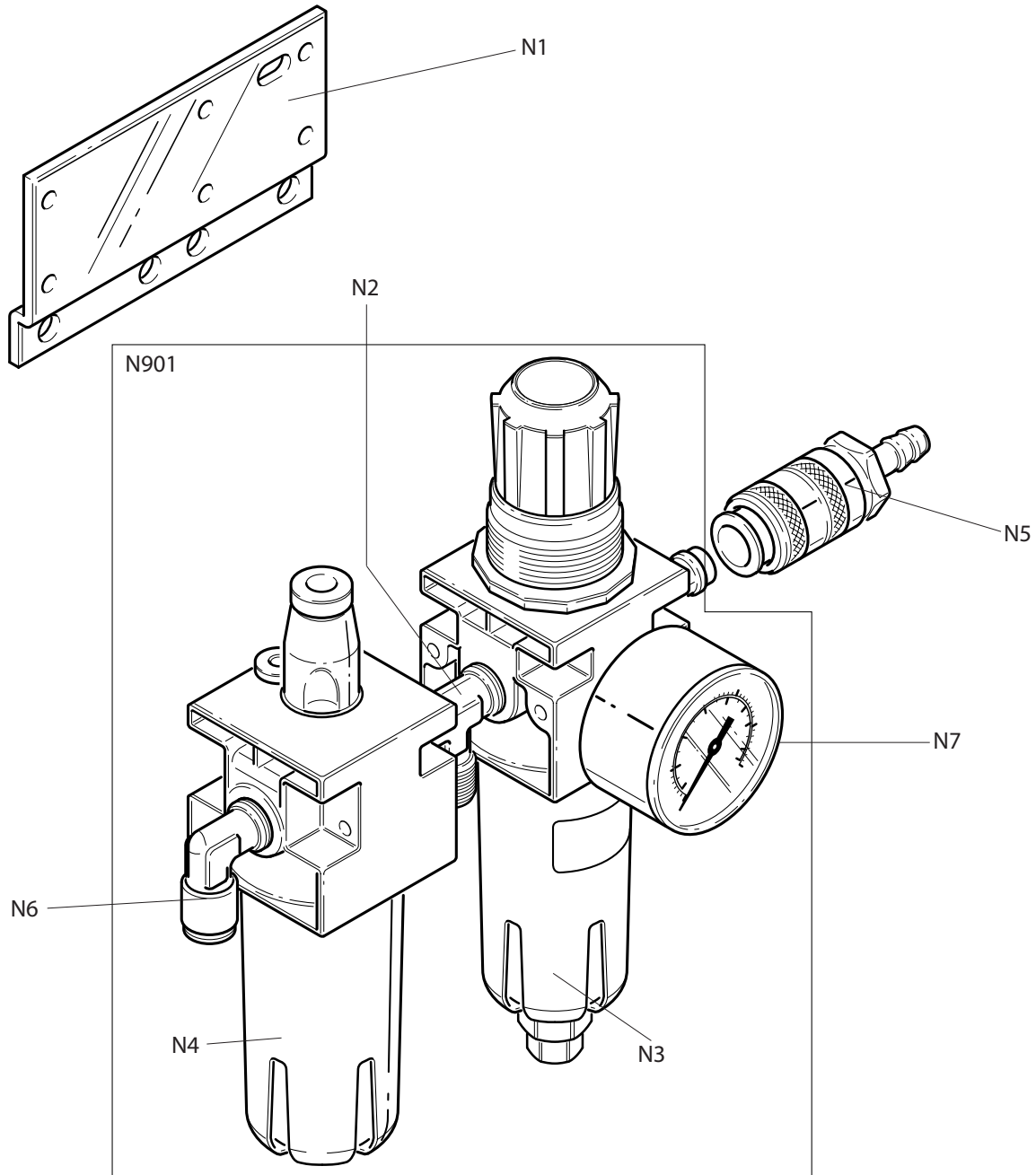

IMPORTANTE: per la richiesta dei ricambi far riferimento al codice ricambi (vedi pag. 26).
IMPORTANT: for the request of spare parts please refer to spare parts code (see page 26).
IMPORTANT: pour la demande de pièces de rechange faire référence au code des pièces de rechange (voir pages 26).
WICHTIG: für die Anforderung von Ersatzteilen die Ersatzteilcodes (siehe Seite 26) angeben.
IMPORTANTE: para pedir los repuestos remitirse al código repuestos (ver pag. 26).

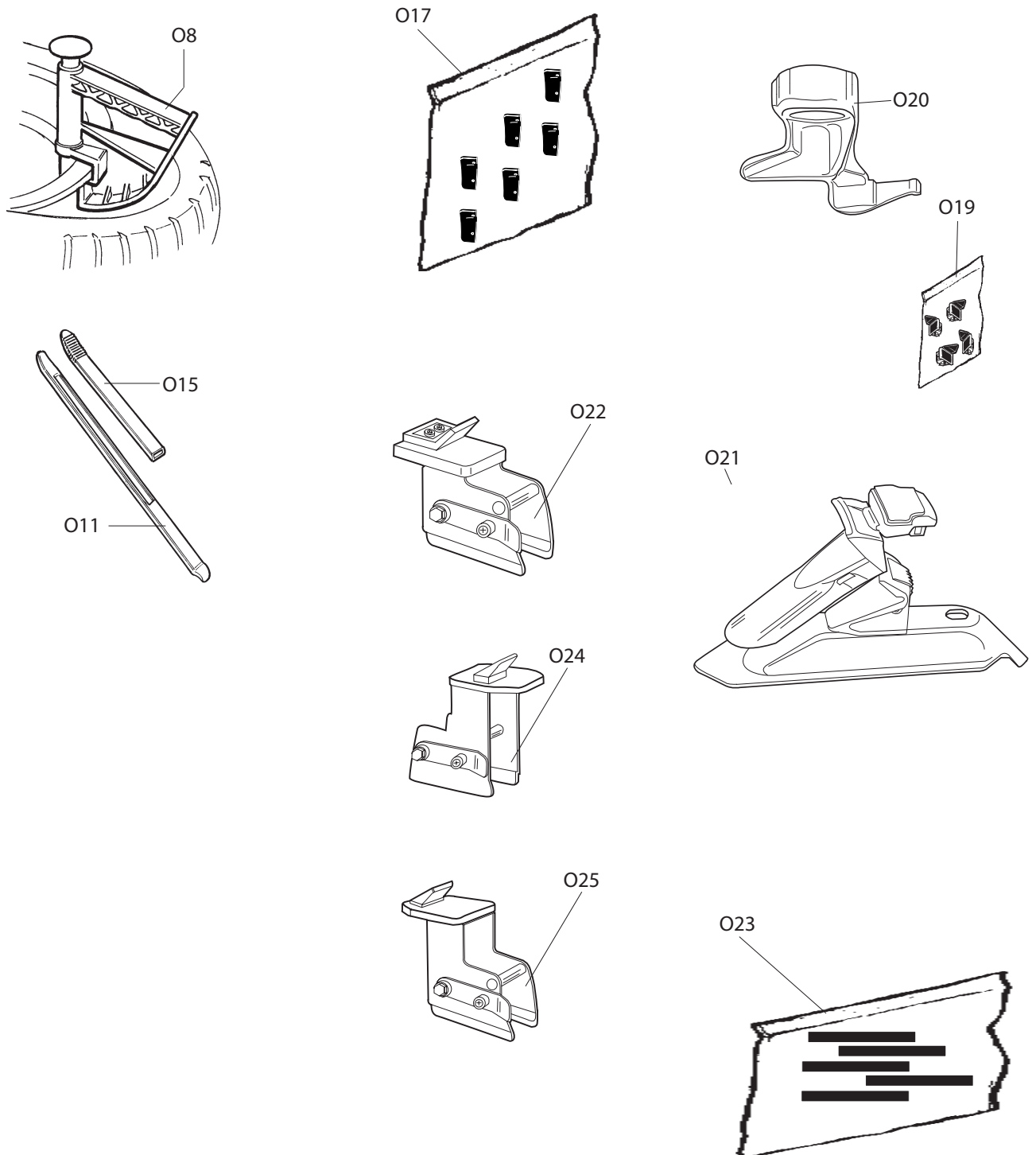

IMPORTANTE: per la richiesta dei ricambi far riferimento al codice ricambi (vedi pag. 26).
IMPORTANT: for the request of spare parts please refer to spare parts code (see page 26).
IMPORTANT: pour la demande de pièces de rechange faire référence au code des pièces de rechange (voir pages 26).
WICHTIG: für die Anforderung von Ersatzteilen die Ersatzteilcodes (siehe Seite 26) angeben.
IMPORTANTE: para pedir los repuestos remitirse al código repuestos (ver pag. 26).





TABELLA RICAMBI
SPARE PARTS CODE
TABLE PIECES DE RECHANGE
ERSATZTEILLISTE
TABLA REPUESTOS

AS 944

Posizione Position Position Position Posicion	Codice ricambio Spare parts code Code rechanger Ersatzteilcode Codigo repuesto	Descrizione Description Description Beschreibung Descripción	Posizione Position Position Position Posicion	Codice ricambio Spare parts code Code rechanger Ersatzteilcode Codigo repuesto	Descrizione Description Description Beschreibung Descripción
TAV. A			B15	9005-100353	TORRETTA HEAD
A1	9004-102137	PROTEZIONE SHIELD	B16	900350194	RONDELLA WASHER
A2	9004-102277	COFANO HOOD	B17	900428681	ANELLO RING
A4	9004-102365	PERNO PIN	B18	9004-101998	BRACCIO ARM
A5	900326169	SUPPORTO SUPPORT	B19	9004-102006	PERNO PIN
A6	90035011564	PIEDE FOOT	B20	9004-102007	RULLO ROLLER
A7	90035016507	APPOGGIO RIM SUPPORT	B21	900239806	PISTONE PISTON
A8	900346545	PROTEZIONE SHIELD	B22	900414859	RACCORDO CONNECTOR
A9	9004-102260	PROTEZIONE SHIELD	B23	90032020007	CILINDRO CYLINDER
TAV. B / Ba			B24	90035020035	COPERCHIO COVER
B1	900463167	MOLLA SPRING	B25	90035020003	CARTER CARTER
B2	900426763	GUIDA GUIDE	B26	9004-102234	CARTER CARTER
B3	9004-102002	PIASTRA SLAB	B27	9005-100682	VALVOLA VALVE
B4	900431061	BOCCOLA BUSHING	B28	9005-100901	MANIGLIA COMANDO LOCKING HANDLE
B5	9004-102342	PULSANTE PUSH BUTTON	B29	900350197	VITE SCREW
B6	9004-102005	PIASTRA SLAB	Ba29	9004-102225	VITE SCREW
Ba6	9004-102226	PIASTRA SLAB	Ba30	9004-102300	PIASTRA PLATE
B7	9005-100681	VALVOLA VALVE	Ba31	9005-100609	CILINDRO CYLINDER
B8	9004-102138	COPERCHIO COVER	Ba32	9004-102301	MOLLA SPRING
B9	900326537	CILINDRO CYLINDER	Ba33	9004-102299	BOCCOLA BUSHING
Ba9	900431257	MOLLA SPRING	Ba34	9004-102222	PERNO PIN
B10	900239805	PISTONE PISTON			
Ba10	9004-102304	PERNO PIN			
B11	900414842	RACCORDO CONNECTOR			
B12	9005-100564	CILINDRO CYLINDER			
B13	9004-102370	PERNO PIN			
B14	900241484	KIT GUARNIZIONI SEAL KIT			

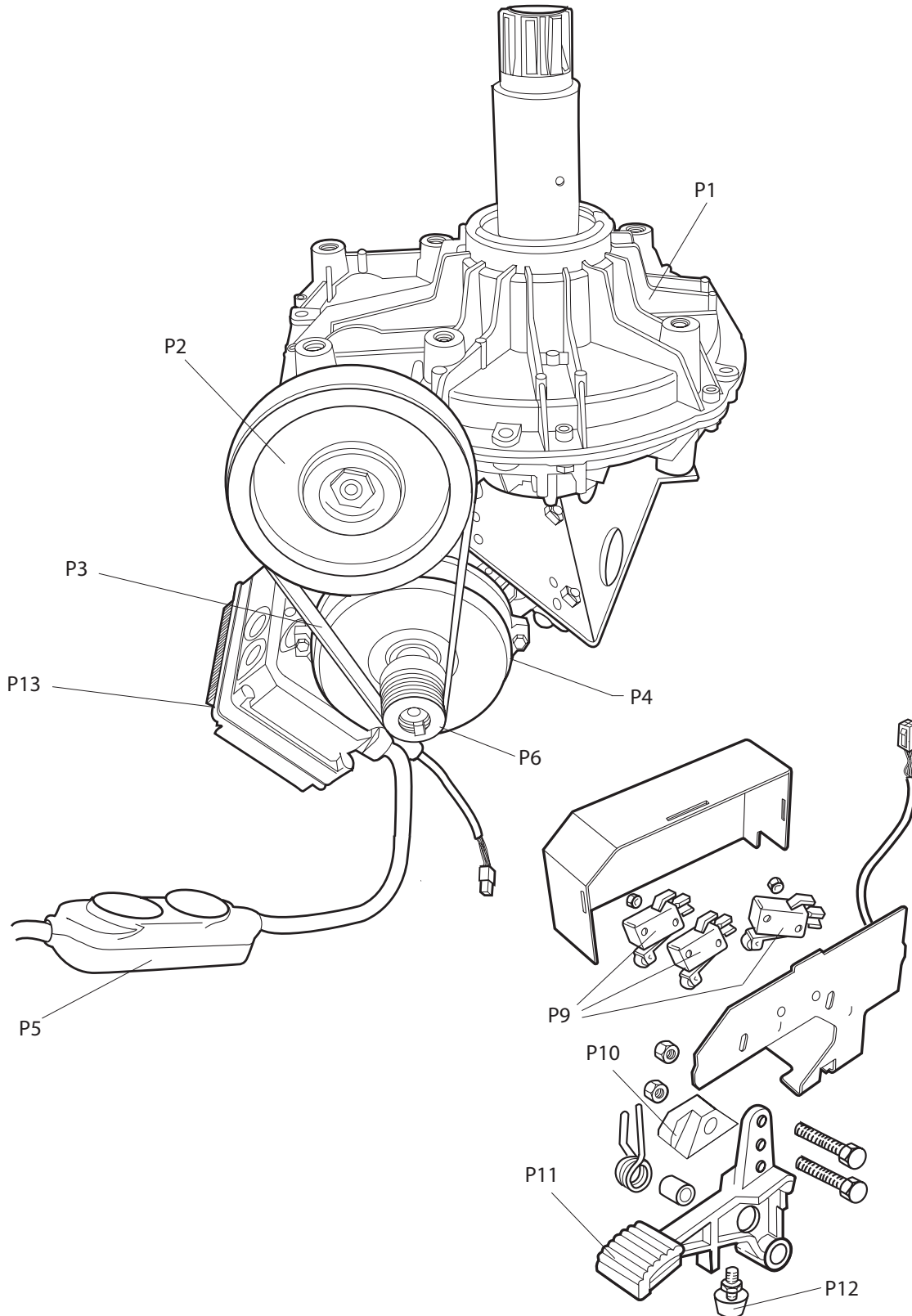

TABELLA RICAMBI
 SPARE PARTS CODE
 TABLE PIECES DE RECHANGE
 ERSATZTEILLISTE
 TABLA REPUESTOS

AS 944

Posizione Position Position Position Posicion	Codice ricambio Spare parts code Code rechanger Ersatzteilcode Codigo repuesto	Descrizione Description Description Beschreibung Descripción	Posizione Position Position Position Posicion	Codice ricambio Spare parts code Code rechanger Ersatzteilcode Codigo repuesto	Descrizione Description Description Beschreibung Descripción
TAV. C			TAV. C (segue)		
C14	900249882	110V 1ph	C8	900422013	MOTORE 3ph 400V MOTOR 3ph 400V
C1	900435363	INVERTITORE REVERSER	C8	900426793	MOTORE 3ph 440V MOTOR 3ph 440V
C2	900230709	CAVO CABLE	C8	900449747	MOTORE 50Hz 1ph 230V MOTOR 50Hz 1ph
C3	900225419	CAVO CABLE	C8	900449749	MOTORE 60Hz 1ph 110V MOTOR 60Hz 1ph
C5	900430750	CAPPELLOTTO CAP NUT	C9	900432009	CINGHIA BELT
C6	900449751	CONDENSATORE CAPACITOR	C10	900334768	CULLA CRADLE
C7	900430770	RESISTENZA RESISTANCE	C11	900331067	PULEGGIA PULLEY
C14	900249881	220V 1ph	C12	900432065	PROTEZIONE SHIELD
C1	900421523	INVERTITORE REVERSER	C13	900430991	COPERCHIO LID
C2	900235520	CAVO CABLE			
C3	900225419	CAVO CABLE			
C5	900414850	CAPPELLOTTO CAP NUT			
C6	900449750	CONDENSATORE CAPACITOR			
C7	900430770	RESISTENZA RESISTANCE			
C14	900235574	3ph			
C1	900421523	INVERTITORE REVERSER			
C2	900235518	CAVO CABLE			
C3	900225390	CAVO CABLE			



TABELLA RICAMBI
 SPARE PARTS CODE
 TABLE PIECES DE RECHANGE
 ERSATZTEILLISTE
 TABLA REPUESTOS

AS 944

Posizione Position Position Position Posicion	Codice ricambio Spare parts code Code rechanger Ersatzteilcode Codigo repuesto	Descrizione Description Description Beschreibung Descripción	Posizione Position Position Position Posicion	Codice ricambio Spare parts code Code rechanger Ersatzteilcode Codigo repuesto	Descrizione Description Description Beschreibung Descripción
TAV. D			TAV. D (segue)		
D100	900233678	PEDALIERA CONTROL PEDAL	D30	900257137	RUBINETTO COCK
D1	900422682	SILENZIATORE SILENCER			
D3	900325019	BALESTRA LEAF SPRING			
D4	900425020	CAMMA CAM			
D5	900325018	CAVALLOTTO U-BOLT			
D6	900425014	BIELLA TRACE			
D8	900419888	RONDELLA WASHER			
D9	900309358	RONDELLA WASHER			
D10	900325005	PERNO PIN			
D11	900410628	MOLLA SPRING			
D12	900325031	PEDALE PEDAL			
D13	900325032	PEDALE PEDAL			
D14	900325050	DISTANZIALE SPACER			
D15	900252010	PEDALE PEDAL			
D16	900425010	BIELLA TRACE			
D17	900425027	LEVA LEVER			
D18	900332495	CAVALLOTTO U-BOLT			
D19	900253298	RUBINETTO COCK			
D22	900428682	MOLLA SPRING			
D23	900433675	REGOLATORE REGULATOR			
D25	900325030	PEDALE PEDAL			
D26	900452011	BOCCOLA BUSHING			
D27	900317610	TUBO PIPE			
D28	900383173	TAPPO PLUG			



TABELLA RICAMBI
 SPARE PARTS CODE
 TABLE PIECES DE RECHANGE
 ERSATZTEILLISTE
 TABLA REPUESTOS

AS 944

Posizione Position Position Position Posicion	Codice ricambio Spare parts code Code rechanger Ersatzteilcode Codigo repuesto	Descrizione Description Description Beschreibung Descripción	Posizione Position Position Position Posicion	Codice ricambio Spare parts code Code rechanger Ersatzteilcode Codigo repuesto	Descrizione Description Description Beschreibung Descripción
TAV. E			TAV. E (segue)		
E1	900323903	PERNO PIN	E30	9004-106071	DADO NUT
E2	90033017256	PERNO PIN	TAV. F		
E3	9004-103908	BRACCIO STALLONATORE BEAD-BREAKER ARM	F50	900233704	RIDUTTORE GEAR BOX
E4	90036020245	VITE REG. BRACCIO STALL. BEAD-BREAKER ARM SCREW	F61	900414344	PULEGGIA PULLEY
E5	90035015286	FINECORSA STOP SHOCKPROOF PLUG	F6	900228389	RACCORDO CONNECTOR
E6	9004-104313	MOLLA SPRING	F7	900238204	KIT GUARNIZIONI SEALS KIT
E9	900351905	FONDELLO CILINDRO CYLINDER BOTTOM			
E10	900325561	RONDELLA WASHER			
E12	900330190	CANNA CILINDRO CYLINDER LINER			
E13	900600989	DADO NUT			
E14	900337848	PISTONE MONOBLOCCO ENBLOCK PISTON			
E15	9002-02510	SEEGER SEEGER			
E17	9004-103920	STELO CILINDRO CYLINDER STEM			
E18	9005-101261	CILINDRO STALLONATORE BEAD-BREAKER CYLINDER			
E19	9004-102689	PALA STALLONATORE BEAD-BREAKER BLADE			
E20	90087221002	IMPUGNATURA HANDLE			
E21	900600047	COPIGLIA SPLIT PIN			
E22	9002-01045	RONDELLA WASHER			
E23	900600992	DADO NUT			
E24	9003-00050	RACCORDO AIR UNION			
E25	900431864	GRANO DOWEL			
E26	900238212	KIT GUARNIZIONI SEALS KIT			
E27	900451926	RACCORDO CONNECTOR			
E28	9002-02670	VITE SCREW			
E29	9002-02166	DADO NUT			



TABELLA RICAMBI
 SPARE PARTS CODE
 TABLE PIECES DE RECHANGE
 ERSATZTEILLISTE
 TABLA REPUESTOS

AS 944

Posizione Position Position Position Posicion	Codice ricambio Spare parts code Code rechanger Ersatzteilcode Codigo repuesto	Descrizione Description Description Beschreibung Descripción	Posizione Position Position Position Posicion	Codice ricambio Spare parts code Code rechanger Ersatzteilcode Codigo repuesto	Descrizione Description Description Beschreibung Descripción
TAV. G			TAV. H		
G1	900426514	TAPPO PLUG	H1	900426514	TAPPO PLUG
G2	900323363	RONDELLA WASHER	H2	900323363	RONDELLA WASHER
G13	900238548	KIT GUARNIZIONI SEALS KIT	H13	900238548	KIT GUARNIZIONI SEALS KIT
G3	9005-100522	AUTOCENTRANTE TURNTABLE	H3	9005-100384	AUTOCENTRANTE TURNTABLE
G10	900428636	RONDELLA WASHER	H10	900428636	RONDELLA WASHER
G19	9004-101438	PIATTO PLATE	H19	9004-101438	PIATTO PLATE
G24	9002-03295	VITE SCREW	H24	9002-03295	VITE SCREW
G25	9004-101651	FLANGIA FLANGE	H25	9004-101651	FLANGIA FLANGE
G26	900601059	SPINA PLUG	H26	900601059	SPINA PLUG
G27	900337965	BOCCOLA BUSHING	H27	900337965	BOCCOLA BUSHING
G35	900455082	RONDELLA WASHER	H35	900455082	RONDELLA WASHER
G36	900601216	VITE SCREW	H36	900601216	VITE SCREW
G37	9003008225	CUNEO JAW	H37	9003008225	CUNEO JAW
G38	9004-101872	SCORREVOLE SLIDER	H38	9004-101871	SCORREVOLE SLIDER
G40	9004-102891	SLITTA SLIDE	H40	9004-102891	SLITTA SLIDE
G41	9004-101721	SUPPORTO SCORREVOLE SLIDER	H41	9004-101721	SUPPORTO SCORREVOLE SLIDER
G42	9004-101442	PERNO PIN	H42	9004-101442	PERNO PIN
G43	9004-101447	MANOVELLA HANDLE	H43	9004-101447	MANOVELLA HANDLE
G44	9004-101443	POMOLO KNOB	H44	9004-101443	POMOLO KNOB
G45	9004-101122	SUPPORTO SCORREVOLE SLIDER	H45	9004-101122	SUPPORTO SCORREVOLE SLIDER
G48	9004-101422	MOLLA SPRING	H46	9004-101918	UGELLO NOZZLE
G49	9004-101444	INNESTO PIN	H47	9003-00050	RACCORDO FITTING
G4	9005-100455	CILINDRO DESTRO CYLINDER RIGHT	H48	9004-101422	MOLLA SPRING
G4	9005-100454	CILINDRO SINISTRO CYLINDER LEFT	H49	9004-101444	INNESTO PIN
G32	9003-02045	RACCORDO DRITTO FITTING	H4	9005-100455	CILINDRO DESTRO CYLINDER RIGHT
G33	9003-02044	RACCORDO A 90° 90° FITTING	H4	9005-100454	CILINDRO SINISTRO CYLINDER LEFT
			H32	9003-02045	RACCORDO DRITTO FITTING
			H33	9003-02044	RACCORDO A 90° 90° FITTING



TABELLA RICAMBI
SPARE PARTS CODE
TABLE PIECES DE RECHANGE
ERSATZTEILLISTE
TABLA REPUESTOS

AS 944

Posizione Position Position Position Posicion	Codice ricambio Spare parts code Code rechanger Ersatzteilcode Codigo repuesto	Descrizione Description Description Beschreibung Descripción	Posizione Position Position Position Posicion	Codice ricambio Spare parts code Code rechanger Ersatzteilcode Codigo repuesto	Descrizione Description Description Beschreibung Descripción
TAV. I			TAV. L		
Ø6	900701684	TUBO PIPE	L9	900233677	PEDALIERA CONTROL PEDAL
Ø8	900701683	TUBO PIPE	L10	900229957	PEDALE PEDAL
I1	900240968	SERBATOIO TANK	L11	900329058	PIASTRINA PLATE
I2	900435077	VALVOLA VALVE	L12	900331381	BIELLA TRACE
I10	900252625	PEDALE PEDAL	L13	900258456	RUBINETTO COCK
I12	900704223	TUBO PIPE	L14	900322705	TUBO PIPE
I18	900438995	RACCORDO CONNECTOR	L15	900415860	RACCORDO CONNECTOR
I23	900337704	RACCORDO CONNECTOR	Ø 8	900701683	TUBO PIPE
I202	900242290	VALVOLA VALVE	L1	900425238	CINGHIA BELT
I26	900431993	CARTUCCIA CARTRIDGE	L2	900319073	PULEGGIA PULLEY
I27	900438665	RACCORDO CONNECTOR	L2	900414344	PULEGGIA PULLEY
I29	900441651	RACCORDO CONNECTOR	L3	900419142	NIPPLO CONNECTION
I34	900243020	VALVOLA VALVE	L4	900419141	VALVOLA VALVE
I30	900241841	RACCORDO CONNECTOR	L5	900419140	RACCORDO CONNECTOR
I32	900342288	TUBO PIPE	L6	900319135	MOTORE MOTOR
I33	9004-103544	TUBO PIPE	L7	900418350	RACCORDO CONNECTOR
I201	900252568	GRUPPO GONFIAGGIO ASSEMBLY	L8	900319076	PULEGGIA PULLEY
I3	900235463	VALVOLA VALVE	Ø 10	900701875	TUBO PIPE
I4	900452564	VALVOLA VALVE			
I5	900452553	VALVOLA VALVE			
I6	900450406	RACCORDO CONNECTOR			
I7	900418252	NIPPLO CONNECTION			
I8	900421137	INNESTO CLUTCH			
I9	900352614	TUBO ARIA PIPE			
I11	9005-100696	MANOMETRO PSI PRESSURE GAUGE			



TABELLA RICAMBI
 SPARE PARTS CODE
 TABLE PIECES DE RECHANGE
 ERSATZTEILLISTE
 TABLA REPUESTOS

AS 944

Posizione Position Position Position Posicion	Codice ricambio Spare parts code Code rechanger Ersatzteilcode Codigo repuesto	Descrizione Description Description Beschreibung Descripción	Posizione Position Position Position Posicion	Codice ricambio Spare parts code Code rechanger Ersatzteilcode Codigo repuesto	Descrizione Description Description Beschreibung Descripción
TAV. M			TAV. N		
M952	9005-100696	SCATOLA - BAR PSI BOX - BAR PSI	N1	9004-102273	STAFFA BRACKET
M4	900437831	MANOMETRO PRESSURE GAUGE	N2	900433873	RACCORDO CONNECTOR
M5	900329245	TUBO PIPE	N901	900456522	FILTRO FILTER
M6	900352586	BLOCCHETTO BLOCK	N3	900457512	BICCHIERE BOWL
M7	900429536	RACCORDO FITTING	N4	900457511	BICCHIERE BOWL
M9	900354410	TUBO PIPE	N5	900441899	GIUNTO COUPLING
M10	900235463	VALVOLA VALVE	N6	900450406	RACCORDO CONNECTOR
M953	900252558	VALVOLA VALVE	N7	900434818	MANOMETRO PRESSURE GAUGE
M11	900446939	RACCORDO CONNECTOR			
M12	900352557	RACCORDO CONNECTOR			
M13	900452553	VALVOLA VALVE			



TABELLA RICAMBI
 SPARE PARTS CODE
 TABLE PIECES DE RECHANGE
 ERSATZTEILLISTE
 TABLA REPUESTOS

AS 944

Posizione Position Position Position Posicion	Codice ricambio Spare parts code Code rechanger Ersatzteilcode Codigo repuesto	Descrizione Description Description Beschreibung Descripción	Posizione Position Position Position Posicion	Codice ricambio Spare parts code Code rechanger Ersatzteilcode Codigo repuesto	Descrizione Description Description Beschreibung Descripción
TAV. O			TAV. P		
O8	801435685	PINZA PLIERS	P1	900246020	RIDUTTORE GEAR BOX
O11	900444288	LEVA LEVER	P2	900339870	PULEGGIA PULLEY
O15	801246241	PROTEZIONE SHIELD	P3	900440571	CINGHIA BELT
O17	801258383	PROTEZIONE SHIELD	P4	9005-100712	MOTORE MOTOR
O19	801254341	PROTEZIONE SHIELD	P5	9004-101687	CAVO CABLE
O20	801252083	KIT TORRETTA 8" HEAD KIT 8"	P6	9004-102397	PULEGGIA PULLEY
O21	9002200573	KIT INSERTI INSERTS	P9	900440874	MICROINTERRUTTORE MICROSWITCH
O22	8-11100041	ATTACCO ADAPTOR	P10	900461535	CAMMA CAM
O23	801258898	INSERTO INSERT	P11	900252010	PEDALE PEDAL
O24	8-11100042	KIT n° 4 ADATTATORI 8" 8" ADAPTORS KIT	P12	900430496	TAMPONE BUMPER
O25	8-11100036	KIT n° 4 ADATTATORI MOTO MOTORCYCLE ADAPTORS KIT	P13	9004-104102	SCHEDA EL. P.C. BOARD



MONDOLFO FERRO S.p.a.
Viale dell'Industria, 20 - 61037 MONDOLFO (PU) Italy
Tel. 0721.93671 - Fax 0721.930238
info@mondolfoferro.it
www.mondolfoferro.it

